

**KENDRIYA VIDYALAYA SANGATHAN, HYDERABAD REGION**  
**SAMPLE PAPER 01 FOR PERIODIC TEST III EXAM (2017-18)**

SUBJECT: SCIENCE (086)

**BLUE PRINT : CLASS X**

UNIT	Chapter	VSA (1 mark)	SA – I (2 marks)	SA – II (3 marks)	LA (5 marks)	Practical Based Questions	Total	Unit Total
Chemical Substances - Nature and Behaviour	Chemical Reactions and Equations	--	--	3(1)	--	--	3(1)	25(8)
	Acids, Bases and Salts	--	--	3(1)*	--	2(1)	5(2)	
	Metals and Non- metals	--	--	--	5(1)	--	5(1)	
	Carbon and its compounds	--	--	--	5(1)*	2(1)	7(2)	
	Periodic Classification of Elements	--	2(1)	3(1)	--	--	5(2)	
World of Living	Life Process	--	--	3(1)*	--	2(1)	5(2)	23(9)
	Control and Coordination	1(1)	--	--	5(1)	--	8(3)	
	How do organisms reproduce?	1(1)	--	3(1)	--	2(1)	4(2)	
	Heredity and Evolution	--	--	6(2)	--	--	6(2)	
Natural Phenomena <sup>a</sup>	Light - Reflection and Refraction	--	2(1)	3(1)	--	2(1)	7(3)	12(4)
	The Human Eye and the colourful world	--	--	--	5(1)	--	5(1)	
Effects of Current	Electricity	--	--	3(1)	--	2(1)*	5(2)	13(4)
	Magnetic Effects of Electric Current	--	--	3(1)*	5(1)	--	8(2)	
Natural Resources	Our Environment	--	2(1)	--	5(1) <sup>#</sup>	--	7(2)	7(2)
	Management of Natural Resources	--	--	--		--		
<b>Total</b>		<b>2(2)</b>	<b>6(3)</b>	<b>30(10)</b>	<b>30(6)</b>	<b>12(6)</b>	<b>80(27)</b>	<b>80(27)</b>

Note: \* - Internal Choice Questions of same chapter.

# - Internal Choice Questions of two chapters

**KENDRIYA VIDYALAYA SANGATHAN, HYDERABAD REGION**  
**SAMPLE PAPER 01 FOR PERIODIC TEST III EXAM (2017-18)**

**SUBJECT: SCIENCE**

**MAX. MARKS : 80**

**CLASS : X**

**DURATION : 3 HRS**

**General Instructions:**

1. All questions are compulsory.
2. The question paper comprises of **two Sections, A and B**. You are to attempt both the sections.
3. All questions of **Section-A** and **Section-B** are to be attempted separately.
4. There is an internal choice in three questions of three marks each and two question of five marks.
5. Question number **1 to 2** in **Section-A** are **one mark** question. These are to be answered in **one word** or in **one sentence**.
6. Question numbers **3 to 5** in **Section-A** are **two marks** questions. These are to be answered in about **30 words** each.
7. Question numbers **6 to 15** in **Section-A** are **three marks** questions. These are to be answered in about **50 words** each.
8. Question numbers **16 to 21** in **Section-A** are **five marks** questions. These are to be answered in about **70 words** each.
9. Question numbers **22 to 27** in **Section-B** are questions based on practical skills and are **two marks** questions.

**SECTION – A**

1. Where are Nissl's granules found and what is their nature?
2. State what type of method is used for growing jasmine plant.
3. An element 'M' has atomic number 12. (a) Write its electronic configuration. (b) State the group to which 'M' belongs. (c) Is 'M' a metal or a non-metal? (d) Write the formula of its oxide.
4. "Vehicles in this mirror are closer than they appear". Why is this warning printed on the side view mirror of most vehicles?
5. Explain 'biological magnification' with the help of an example.
6. 2 g of ferrous sulphate crystals are heated in a dry boiling tube.
  - (a) List any two observations.
  - (b) Name the type of chemical reaction taking place.
  - (c) Write the chemical equation for the reaction.
7.
  - (a) Name the compound which is obtained from baking soda and is used to remove permanent hardness of water.
  - (b) Write its chemical formula.
  - (c) What happens when it is recrystallised from its aqueous solution?

**OR**

What is tooth enamel chemically? State the condition when it starts corroding. What happens when food particles left in the mouth after eating degrade? Why do doctors suggest use of tooth powder/toothpaste to prevent tooth decay?

8. Write the number of periods the Modern Periodic Table has. State the changes in valency and metallic character of elements as we move from left to right in a period. Also state the changes, if any, in the valency and atomic size of elements as we move down a group.
9. Draw a diagram of human respiratory system and label on it: (a) Diaphragm (b) Larynx

**OR**

Describe the structure and functioning of nephrons.

10. What is AIDS? Which microbe is responsible for AIDS infection? State one mode of transmission of this disease. Explain in brief one measure for the prevention of AIDS.
11. An object of height 6 cm is placed perpendicular to the principal axis of a concave lens of focal length 5 cm. Use lens formula to determine the position, size and nature of the image if the distance of the object from the lens is 10 cm.
12. A circuit is shown in the diagram given below.
- Find the value of R.
  - Find the reading of the ammeter.
  - Find the potential difference across the terminals of the battery.

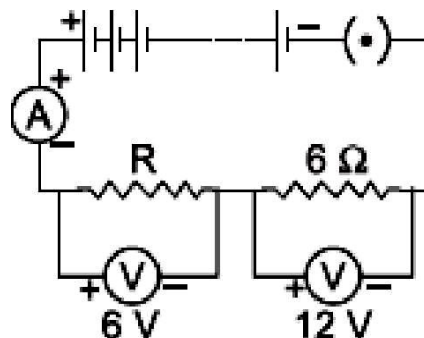

13. What is meant by solenoid? How does a current carrying solenoid behave? Give its main use.

**OR**

State one main difference between AC and DC. Why AC is preferred over DC for long range transmission of electric power? Name one source each of DC and AC.

14. How do Mendel's experiment show that traits are inherited independently?
15. How are fossils formed? Describe, in brief two methods of determining the age of fossils.
16. How is the method of extraction of metals high up in the reactivity series different from that for metals in the middle? Why the same process cannot be applied for them? Explain giving equations, the extraction of sodium.
17. Explain isomerism. State any four characteristics of isomers. Draw the structures of possible isomers of butane,  $C_4H_{10}$ .

**OR**

What are micelles? Why does it form when soap is added to water? Will a micelle be formed in other solvents such as ethanol also? State briefly how the formation of micelles help to clean the clothes having oily spots.

18. What is meant by reflex-action? With the help of a labelled diagram trace the sequence of events which occur when we touch a hot object.
19. An old person finds it difficult to see nearby objects comfortably and distinctly without corrective eye glasses.
- What defect of vision is he suffering from? What is it?
  - List two causes for the development of this defect.
  - What kind of lens will be required to see clearly the nearby as well as distant objects? Give reasons.
  - How is the eye defect of old person differing from near-sightedness and far-sightedness?

20. (a) Explain why there are two separate circuits one for high power rating appliances and other for low power rating appliances.  
 (b) A domestic circuit has 5A fuse. How many bulbs of rating 100W, 220V can be safely used in this circuit? Justify your answer.
21. A non-biodegradable toxic chemical has entered into the food chain. Which type of food habit will you suggest to a man, vegetarian or non-vegetarian? Explain with the help of a food chain. The food chain which you would suggest, is advantageous in an another aspect. How?

OR

Explain the traditional water harvesting system with a suitable diagram. Write about the techniques of water harvesting.

### SECTION – B

22. Name the parts A and C shown in the following diagram and state one function of each.

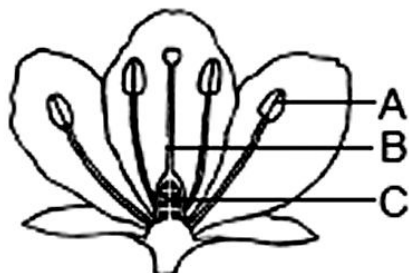

23. A ray of light is refracted as per the following diagram. Which media A or B is optically denser than other?

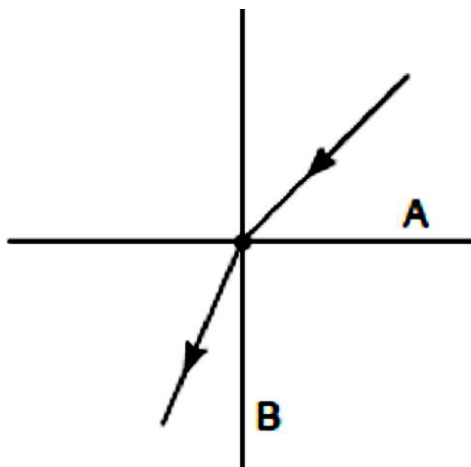

24. 15 mL of water and 10 mL of sulphuric acid are to be mixed in a beaker  
 (a) State the method that should be followed with reason.  
 (b) What is this process called?
25. (a) Write the balanced chemical equation for the process of photosynthesis.  
 (b) When do the desert plants take up carbon dioxide and perform photosynthesis?
26. Atom of an element contains five electrons in its valence shell. This element is major component of air. It exists as a diatomic molecule.  
 (i) Identify the element.  
 (ii) Show the bond formed between two atoms of this element.  
 (iii) Write the nature of the bond between the two atoms.

27. In the given circuit, resistors A and B are made up of same metal and are of the same length but, A is thicker than B.

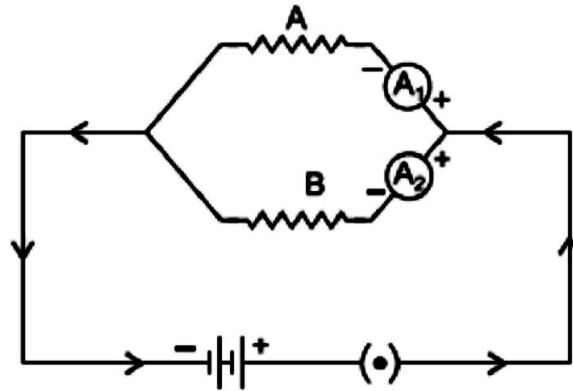

Which of the two ammeters will show a higher reading? Justify your answer.

**OR**

While experimentally verifying Ohm's Law a student observed that the pointer of the voltmeter coincide with 15th division when the voltmeter has a least count of 0.05 V. Find the observed reading of voltmeter.

.....