

# MATHEMATICS

## QUESTION BANK

*for*

*Summative Assessment -II*

CLASS – IX

2015 – 16

**CHAPTER WISE COVERAGE IN THE FORM  
MCQ WORKSHEETS AND PRACTICE QUESTIONSS**

Prepared by

***M. S. KUMARSWAMY, TGT(MATHS)***

***M. Sc. Gold Medallist (Elect.), B. Ed.***

**Kendriya Vidyalaya GaCHIBOWI i**

# PREFACE

It gives me great pleasure in presenting the Question Bank for Summative Assessment (SA) - II. It is in accordance with the syllabus of the session 2015–16 for second term (CCE pattern). It also includes two sets of sample papers at the end based on new question paper pattern.

Each chapter has a large number of multiple-choice questions in the form of Worksheets, which will help students quickly test their knowledge and skill.

A sufficient number of short answer type and long answer type questions are included in the form of PRACTICE QUESTIONS. This Question Bank is also helpful to all the teachers for internal assessment of the students.

Keeping the mind the mental level of a child, every effort has been made to introduce simple multiple choice questions so that the child solve them easily and gets confidence.

I avail this opportunity to convey my sincere thanks to respected sir, Shri U. N. Khaware, Additional Commissioner(Acad), KVS Headquarter, New Delhi, respected sir, Shri S. Vijay Kumar, Joint Commissioner(Admn), KVS Headquarter, New Delhi, respected sir Shri P. V. Sairanga Rao, Deputy Commissioner, KVS Headquarter, New Delhi, respected sir Shri. D. Manivannan, Deputy Commissioner, KVS RO Hyderabad, respected sir Shri Isampal, Deputy Commissioner, KVS RO Bhopal, respected sir Shri P. Deva Kumar, Deputy Commissioner, KVS RO Bangalore, respected sir Shri Nagendra Goyal, Deputy Commissioner, KVS RO Ranchi, respected sir Shri Y. Arun Kumar, Assistant Commissioner(Acad), KVS Headquarter, New Delhi, respected sir Shri Sirimala Sambanna, Assistant Commissioner, KVS RO Hyderabad, respected sir Shri. K. L. Nagaraju, Assistant Commissioner, KVS RO Bangalore, respected sir Shri.Gangadharaiah, Assistant Commissioner, KVS RO Bangalore and respected Shri M.K. Kulshreshtha, Assistant Commissioner, KVS RO Chandigarh for their blessings, motivation and encouragement in bringing out this project in such an excellent form.

I also extend my special thanks to respected sir Shri. P. S. Raju, Principal, KV Gachibowli, respected madam Smt. Nirmala Kumari M., Principal, KV Mysore & respected sir Shri. M. Vishwanatham, Principal, KV Raichur for their kind suggestions and motivation while preparing this Question Bank. I would like to place on record my thanks to respected sir Shri. P. K. Chandran, Principal, presently working in KV Bambolim. I have started my career in KVS under his guidance, suggestions and motivation.

Inspite of my best efforts to make this notes error free, some errors might have gone unnoticed. I shall be grateful to the students and teacher if the same are brought to my notice. You may send your valuable suggestions, feedback or queries through email to [kumarsir34@gmail.com](mailto:kumarsir34@gmail.com) that would be verified by me and the corrections would be incorporated in the next year Question Bank.

***M. S. KUMARSWAMY***

ISAMPAL  
DEPUTY COMMISSIONER



केन्द्रीय विद्यालय संगठन, क्षेत्रीय कार्यालय,  
के. कामराज मार्ग, बेंगलूर-560 042

KENDRIYA VIDYALAYA SANGATHAN  
REGIONAL OFFICE

K. KAMARAJA ROAD, BANGALORE- 560042

F. DO-DC./2013-KVS(BGR)

Dated:05.09.2013

Dear Shri M.S.Kumarswamy,

It has been brought to my notice the good work done by you with regard to making question bank and worksheets for classes VI to X in Mathematics. I am pleased to look at your good work. Mathematics is one discipline which unfortunately and wrongly perceived as a phobia. May be lack of motivation from teachers and inadequate study habits of students is responsible for this state of affairs. Your work in this regard assumes a great significance. I hope your own students as well as students of other Vidyalayas will benefit by your venture. You may mail the material to all the Kendriya Vidyalayas of the region for their benefit. Keep up the good work.

**May God bless!**

Yours sincerely,

(Isampal)

Shri M.S.Kumarswamy  
TGT (Maths)  
Kendriya Vidyalaya  
Donimalai

Copy to: the principals, Kendriya Vidyalayas, Bangalore Region with instructions to make use of the materials prepared by Mr. M.S.Kumarswamy being forwarded separately.

**DEDICATED**  
**TO**  
**MY FATHER**  
**LATE SHRI. M. S. MALLAYYA**



# INDEX

S. No.	Chapter	Page No.
<b>1</b>	<b>SYLLABUS</b>	
<b>2</b>	<b>Linear Equation in two variables</b>	
	MCQ Worksheets – I to III	1 – 3
	Practice Questions	4 – 8
<b>3</b>	<b>Quadrilaterals</b>	
	MCQ Worksheets – I to IV	9 – 16
	Practice Questions	17 – 23
<b>4</b>	<b>Areas of Parallelograms and triangles</b>	
	MCQ Worksheets – I to IV	24 – 30
	Practice Questions	31 – 38
<b>5</b>	<b>Circles</b>	
	MCQ Worksheets – I to IV	39 – 44
	Practice Questions	45 – 52
<b>6</b>	<b>Constructions</b>	
	MCQ Worksheets – I	53
	Practice Questions	54
<b>7</b>	<b>Surface areas and Volumes</b>	
	MCQ Worksheets – I – VI	55 – 61
	Practice Questions	62 – 66
<b>8</b>	<b>Statistics</b>	
	MCQ Worksheets – I to IV	67 – 70
	Practice Questions	72 – 77
<b>9</b>	<b>Probability</b>	
	MCQ Worksheets – I – IV	78 – 84
	Practice Questions	85 – 87
<b>10</b>	Sample Paper – 01	88 – 92
<b>11</b>	Sample Paper – 02	93 – 97

**SYLLABUS FOR 2<sup>ND</sup> TERM 2015 – 16**  
**Course Structure**  
**Class IX**

<b>First Term</b>	<b>Marks : 90</b>
<b>UNITS</b>	<b>MARKS</b>
II ALGEBRA	10
III GEOMETRY (Contd.)	38
V MENSURATION (Contd.)	22
VI PROBABILITY	08
VII STATISTICS	12
<b>TOTAL</b>	<b>90</b>

*The test of OTBA for SA-II will be from Unit-II Linear Equation in Two variables*

**UNIT II : ALGEBRA (Contd.)**

**2. LINEAR EQUATIONS IN TWO VARIABLES**

**(14) Periods**

Recall of linear equations in one variable. Introduction to the equation in two variables. Prove that a linear equation in two variables has infinitely many solutions and justify their being written as ordered pairs of real numbers, plotting them and showing that they seem to lie on a line. Examples, problems from real life, including problems on Ratio and Proportion and with algebraic and graphical solutions being done simultaneously

**UNIT III : GEOMETRY (Contd.)**

**4. QUADRILATERALS**

**(10) Periods**

1. (Prove) The diagonal divides a parallelogram into two congruent triangles.
2. (Motivate) In a parallelogram opposite sides are equal, and conversely.
3. (Motivate) In a parallelogram opposite angles are equal, and conversely.
4. (Motivate) A quadrilateral is a parallelogram if a pair of its opposite sides is parallel and equal.
5. (Motivate) In a parallelogram, the diagonals bisect each other and conversely.
6. (Motivate) In a triangle, the line segment joining the mid points of any two sides is parallel to the third side and (motivate) its converse.

**5. AREA**

**(4) Periods**

Review concept of area, recall area of a rectangle.

1. (Prove) Parallelograms on the same base and between the same parallels have the same area.
2. (Motivate) Triangles on the same base and between the same parallels are equal in area and its converse.

**6. CIRCLES**

**(15) Periods**

Through examples, arrive at definitions of circle related concepts, radius, circumference, diameter, chord, arc, subtended angle.

1. (Prove) Equal chords of a circle subtend equal angles at the center and (motivate) its converse.
2. (Motivate) The perpendicular from the center of a circle to a chord bisects the chord and conversely, the line drawn through the center of a circle to bisect a chord is perpendicular to the chord.
3. (Motivate) There is one and only one circle passing through three given non-collinear points.

4. (Motivate) Equal chords of a circle (or of congruent circles) are equidistant from the center(s) and conversely.
5. (Prove) The angle subtended by an arc at the center is double the angle subtended by it at any point on the remaining part of the circle.
6. (Motivate) Angles in the same segment of a circle are equal.
7. (Motivate) If a line segment joining two points subtends equal angle at two other points lying on the same side of the line containing the segment, the four points lie on a circle.
8. (Motivate) The sum of the either pair of the opposite angles of a cyclic quadrilateral is  $180^\circ$  and its converse

## **7. CONSTRUCTIONS**

**(10) Periods**

1. Construction of bisectors of line segments & angles,  $60^\circ$ ,  $90^\circ$ ,  $45^\circ$  angles etc., equilateral triangles.
2. Construction of a triangle given its base, sum/difference of the other two sides and one base angle.
3. Construction of a triangle of given perimeter and base angles.

## **UNIT V : MENSURATION (Contd.)**

### **2. SURFACE AREAS AND VOLUMES**

**(12) Periods**

Surface areas and volumes of cubes, cuboids, spheres (including hemispheres) and right circular cylinders/cones.

## **UNIT VI : STATISTICS AND PROBABILITY**

### **1. STATISTICS**

**(13) Periods**

Introduction to Statistics : Collection of data, presentation of data — tabular form, ungrouped / grouped, bar graphs, histograms (with varying base lengths), frequency polygons, qualitative analysis of data to choose the correct form of presentation for the collected data. Mean, median, mode of ungrouped data.

### **2. PROBABILITY**

**(12) Periods**

History, Repeated experiments and observed frequency approach to probability. Focus is on empirical probability. (A large amount of time to be devoted to group and to individual activities to motivate the concept; the experiments to be drawn from real - life situations, and from examples used in the chapter on statistics).

.....

**MCQ WORKSHEET-I**  
**CLASS IX: CHAPTER – 4**  
**LINEAR EQUATION IN TWO VARIABLES**

1. The solution of the equation  $x - 2y = 4$  is:  
(a) (0, 2)      (b) (4, 0)      (c) (1, 1)      (d) (2, 0)
2. In graphical representation of  $y = -4$ , line is:  
(a) parallel to  $x$  – axis      (b) parallel to  $y$  – axis  
(c) passes through origin      (d) None of these.
3. Solution of the equation  $2x + 1 = x + 3$  is:  
(a) 3      (b) 1      (c) 2      (d) 4
4. The graph of line  $x - y = 0$  passes through:  
(a) (2, 3)      (b) (3, 4)      (c) (5, 6)      (d) (0, 0)
5. The graph of line  $x + y = 7$  intersect the  $x$ -axis at:  
(a) (7, 0)      (b) (0, 7)      (c) (-7, 0)      (d) (0, -7)
6. Point (4, 1) lies on the line:  
(a)  $x + 2y = 5$       (b)  $x + 2y = -6$       (c)  $x + 2y = 6$       (d)  $x + 2y = 16$
7. Graph of  $x = 2$  is a line:  
(a) parallel to  $x$  – axis      (b) parallel to  $y$  – axis  
(c) passes through origin      (d) None of these.
8. The linear equation  $2x - 5y = 7$  has  
(a) a unique solution      (b) two solutions  
(c) infinitely many solutions      (d) no solutions.
9. The equation  $2x + 5y = 7$  has a unique solution, if  $x, y$  are:  
(a) natural numbers      (b) positive numbers  
(c) real numbers      (d) rational numbers.
10. If (2, 0) is a solution of the linear equation  $2x + 3y = k$ , then the value of  $k$  is  
(a) 4      (b) 6      (c) 5      (d) 2
11. Any solution of the linear equation  $2x + 0y + 9 = 0$  in two variables is of the form  
(a)  $(-\frac{9}{2}, m)$       (b)  $(n, -\frac{9}{2})$       (c)  $(0, -\frac{9}{2})$       (d)  $(-9, 0)$
12. The graph of the linear equation  $2x + 3y = 6$  cuts the  $y$ -axis at the point  
(a) (2, 0)      (b) (0, 3)      (c) (3, 0)      (d) (0, 2)
13. The equation  $x = 7$ , in two variables, can be written as  
(a)  $x + 0y = 7$       (b)  $0x + y = 7$       (c)  $0x + 0y = 7$       (d)  $x + y = 7$
14. Any point on the  $x$  – axis is of the form  
(a)  $(x, y)$       (b)  $(0, y)$       (c)  $(x, 0)$       (d)  $(x, x)$

**MCQ WORKSHEET-II**  
**CLASS IX: CHAPTER – 4**  
**LINEAR EQUATION IN TWO VARIABLES**

1. Any point on the  $y = x$  is of the form  
(a)  $(a, a)$       (b)  $(0, a)$       (c)  $(a, 0)$       (d)  $(a, -a)$
2. The equation of  $x$  –axis is of the form  
(a)  $x = 0$       (b)  $y = 0$       (c)  $x + y = 0$       (d)  $x = y$
3. Graph of  $y = 6$  is a line:  
(a) parallel to  $x$  – axis at a distance 6 units from the origin  
(b) parallel to  $y$  – axis at a distance 6 units from the origin  
(c) making an intercept 6 on the  $x$  –axis.  
(d) making an intercept 6 on both the axes.
4.  $x=5, y=2$  is a solution of the linear equation  
(a)  $x + 2y = 7$    (b)  $5x + 2y = 7$       (c)  $x + y = 7$       (d)  $5x + y = 7$
5. If a linear equation has solutions  $(-2, 2), (0, 0)$  and  $(2, -2)$ , then its is of the form  
(a)  $y - x = 0$    (b)  $x + y = 0$    (c)  $-2x + y = 0$       (d)  $-x + 2y = 0$
6. The positive solutions of the equation is  $ax + by + c = 0$  always lie in the  
(a) 1<sup>st</sup> quadrant      (b) 2<sup>nd</sup> quadrant      (c) 3<sup>rd</sup> quadrant      (d) 4<sup>th</sup> quadrant
7. The graph of the linear equation  $2x + 3y = 6$  is a line which meets the  $x$  axis at the point  
(a)  $(2, 0)$       (b)  $(0, 3)$       (c)  $(3, 0)$       (d)  $(0, 2)$
8. The graph of the  $y = x$  passes through the point  
(a)  $\left(\frac{3}{2}, -\frac{3}{2}\right)$    (b)  $\left(0, \frac{3}{2}\right)$       (c)  $(1, 1)$       (d)  $\left(\frac{-1}{2}, \frac{1}{2}\right)$
9. If we multiply or divide both sides of a linear equation with a non-zero number, then the solution of the linear equation:  
(a) changes      (b) remains the same  
(c) changes in case of multiplication only      (d) changes in case of division only
10. How many linear equation in  $x$  and  $y$  can be satisfied by  $x = 1$  and  $y = 2$ ?  
(a) only one      (b) two      (c) infinitely many      (d) three
11. The point of the form  $(a, a)$  always lies on:  
(a)  $x$  – axis      (b)  $y$  – axis      (c) on the line  $y = x$       (d) on the  $x + y = 0$
12. The point of the form  $(a, -a)$  always lies on:  
(a)  $x = a$       (b)  $y = -a$       (c)  $y = x$       (d)  $x + y = 0$

**MCQ WORKSHEET-III**  
**CLASS IX: CHAPTER – 4**  
**LINEAR EQUATION IN TWO VARIABLES**

1. Which of the following is not a linear equation in two variables?  
(a)  $ax + by = c$     (b)  $ax^2 + by = c$     (c)  $2x + 3y = 5$     (d)  $3x + 2y = 6$
  2. The graph of  $ax + by + c = 0$  is  
(a) a straight line parallel to x-axis    (b) a straight line parallel to y-axis  
(c) a general straight line    (d) a line in the 2<sup>nd</sup> and 3<sup>rd</sup> quadrant
  3. The solution of a linear equation in two variables is  
(a) a number which satisfies the given equation  
(b) an ordered pair which satisfies the given equation  
(c) an ordered pair, whose respective values when substituted for x and y in the given equation, satisfies it  
(d) none of these
  4. One of the solution of a linear equation in two variables is  
(a) (3, 2)    (b) (3, -2)    (c) (2, 3)    (d) (-2, -3)
  5. The ordered pair (m, n) satisfies the equation  $ax + by + c = 0$  if  
(a)  $am + bn = 0$     (b)  $c = 0$     (c)  $am + bn + c = 0$     (d)  $am + bn - c = 0$
  6. The equation of x – axis is  
(a)  $a = 0$     (b)  $y = 0$     (c)  $x = 0$     (d)  $y = k$
  7. From the graph of a line, we can find the coordinates of  
(a) only two point lying on the line  
(b) only two points only lying on the line.  
(c) only finite number of points lying on the line.  
(d) only infinite number of points lying on the line.
  8. A linear equation in two variables has  
(a) no solution    (b) only one solution    (c) only two solutions    (d) infinitely many solutions
  9. An equation of the form  $ax + by + c = 0$  represents a linear equation in two variables, if  
(a)  $a = 0, b \neq 0$     (b)  $a \neq 0, b = 0$     (c)  $a = 0, b = 0$     (d)  $a = 0, b \neq 0$
  10. The graph of the linear equation in two variables  $y = mx$  is  
(a) a line parallel to x – axis    (b) a line parallel to y – axis  
(c) a line passing through the origin    (d) not a straight line
- .....

**PRACTICE QUESTIONS**  
**CLASS IX: CHAPTER – 4**  
**LINEAR EQUATION IN TWO VARIABLES**

1. Find the value of  $k$ , if  $x = 2$ ,  $y = 1$  is a solution of the equation  $2x + 3y = k$ .
2. Find the points where the graph of the equation  $3x + 4y = 12$  cuts the  $x$ -axis and the  $y$ -axis.
3. At what point does the graph of the linear equation  $x + y = 5$  meet a line which is parallel to the  $y$ -axis, at a distance 2 units from the origin and in the positive direction of  $x$ -axis.
4. Determine the point on the graph of the equation  $2x + 5y = 20$  whose  $x$ -coordinate is  $\frac{5}{2}$  times its ordinate.
5. Draw the graph of the equation represented by the straight line which is parallel to the  $x$ -axis and is 4 units above it.
6. Draw the graphs of linear equations  $y = x$  and  $y = -x$  on the same cartesian plane. What do you observe?
7. Determine the point on the graph of the linear equation  $2x + 5y = 19$ , whose ordinate is  $1\frac{1}{2}$  times its abscissa.
8. Draw the graph of the equation represented by a straight line which is parallel to the  $x$ -axis and at a distance 3 units below it.
9. Draw the graph of the linear equation whose solutions are represented by the points having the sum of the coordinates as 10 units.
10. Write the linear equation such that each point on its graph has an ordinate 3 times its abscissa.
11. If the point  $(3, 4)$  lies on the graph of  $3y = ax + 7$ , then find the value of  $a$ .
12. How many solution(s) of the equation  $2x + 1 = x - 3$  are there on the : (i) Number line (ii) Cartesian plane
13. Find the solution of the linear equation  $x + 2y = 8$  which represents a point on (i)  $x$ -axis (ii)  $y$ -axis
14. For what value of  $c$ , the linear equation  $2x + cy = 8$  has equal values of  $x$  and  $y$  for its solution.
15. Let  $y$  varies directly as  $x$ . If  $y = 12$  when  $x = 4$ , then write a linear equation. What is the value of  $y$  when  $x = 5$ ?
16. Draw the graph of the linear equation  $2x + 3y = 12$ . At what points, the graph of the equation cuts the  $x$ -axis and the  $y$ -axis?
17. Show that the points A  $(1, 2)$ , B  $(-1, -16)$  and C  $(0, -7)$  lie on the graph of the linear equation  $y = 9x - 7$ .

18. The following values of  $x$  and  $y$  are thought to satisfy a linear equation :

$x$	1	2
$y$	1	3

Draw the graph, using the values of  $x$ ,  $y$  as given in the above table. At what point the graph of the linear equation (i) cuts the  $x$ -axis. (ii) cuts the  $y$ -axis.

19. The Autorikshaw fare in a city is charged Rs 10 for the first kilometer and @ Rs 4 per kilometer for subsequent distance covered. Write the linear equation to express the above statement. Draw the graph of the linear equation.

20. The work done by a body on application of a constant force is the product of the constant force and the distance travelled by the body in the direction of force. Express this in the form of a linear equation in two variables and draw its graph by taking the constant force as 3 units. What is the work done when the distance travelled is 2 units. Verify it by plotting the graph.

21. The following values of  $x$  and  $y$  are thought to satisfy a linear equation, Write the linear equation.

$x$	6	-6
$y$	-6	6

Draw the graph, using the values of  $x$ ,  $y$  as given in the above table. At what point the graph of the linear equation (i) cuts the  $x$ -axis. (ii) cuts the  $y$ -axis.

22. Draw the graph of the linear equation  $3x + 4y = 6$ . At what points, the graph cuts the  $x$ -axis and the  $y$ -axis.

23. The force exerted to pull a cart is directly proportional to the acceleration produced in the body. Express the statement as a linear equation of two variables and draw the graph of the same by taking the constant mass equal to 6 kg. Read from the graph, the force required when the acceleration produced is (i)  $5 \text{ m/sec}^2$ , (ii)  $6 \text{ m/sec}^2$ .

24. If the temperature of a liquid can be measured in Kelvin units as  $x^\circ\text{K}$  or in Fahrenheit units as  $y^\circ\text{F}$ , the relation between the two systems of measurement of temperature is given by the linear

$$\text{equation } y = \frac{9}{5}(x - 273) + 32$$

- (i) Find the temperature of the liquid in Fahrenheit if the temperature of the liquid is  $313^\circ\text{K}$ .  
(ii) If the temperature is  $158^\circ\text{F}$ , then find the temperature in Kelvin.

25. The linear equation that converts Fahrenheit (F) to Celsius (C) is given by the relation

$$C = \frac{5F - 160}{9}$$

- (i) If the temperature is  $86^\circ\text{F}$ , what is the temperature in Celsius?  
(ii) If the temperature is  $35^\circ\text{C}$ , what is the temperature in Fahrenheit?  
(iii) If the temperature is  $0^\circ\text{C}$  what is the temperature in Fahrenheit and if the temperature is  $0^\circ\text{F}$ , what is the temperature in Celsius?  
(iv) What is the numerical value of the temperature which is same in both the scales?

26. Draw the graph of  $x + y = 7$  and  $x - y = 2$  on the same graph.

27. If the point  $(3, 4)$  lies on the graph of the equation  $3y = ax + 7$ , find the value of  $a$ .

28. The taxi fare in a city is as follows: For the first kilometre, the fare is Rs 8 and for the subsequent distance it is Rs 5 per km. Taking the distance covered as  $x$  km and total fare as Rs  $y$ , write a linear equation for this information, and draw its graph.



29. Solve the equation  $2x + 1 = x - 3$ , and represent the solution(s) on  
 (i) the number line,  
 (ii) the Cartesian plane.
30. Give the geometric representations of  $y = 3$  as an equation  
 (i) in one variable (ii) in two variables
31. Give the geometric representations of  $2x + 9 = 0$  as an equation  
 (i) in one variable (ii) in two variables
32. The force applied on a body is directly proportional to the acceleration produced in the body. Write an equation to express this situation and plot the graph of the equation.
33. Draw the graphs of the equations  $x - y + 1 = 0$  and  $3x + 2y - 12 = 0$ . Determine the coordinates of the vertices of the triangle formed by these lines and the  $x$ -axis, and shade the triangular region.
34. Draw the graphs of the equations  $y = x$  and  $y = -x$  in the same graph paper. Find the coordinates of the point where two lines intersect.
35. Draw the graphs of the equations  $3x - 2y = 4$  and  $x + y - 3 = 0$  in the same graph paper. Find the coordinates of the point where two lines intersect.
36. Draw the graphs of the equations  $3x - 2y + 6 = 0$  and  $x + 2y - 6 = 0$  in the same graph paper. Find the area of triangle formed by the two lines and  $x$  - axis.
37. If the number of hours for which a labourer works is  $x$  and  $y$  are his wages (in rupees) and  $y = 2x - 1$ , draw the graph of work - wages equation. From the graph, find the wages of the labourer if he works for 6 hours.
38. A and B are friends. A is elder to B by 5 years. B's sister C is half the age of B while A's father D is 8 years older than twice the age of B. If the present age of D is 48 years, find the present ages of A, B and C.
39. A three-wheeler scoter charges Rs. 10 for the first km and Rs. 4.50 each for every subsequent km. For a distance of  $x$  km, an amount of Rs.  $Y$  is paid. Write the linear equation representing the above information.
40. Solve:  $5x + \frac{7}{2} = \frac{3}{2}x - 14$
41. Solve:  $\frac{6x+1}{3} + 1 = \frac{x-3}{6}$
42. Solve:  $5x - 2(2x - 7) = 2(3x - 1) + \frac{7}{2}$
43. Solve:  $\frac{3x-2}{4} - \frac{2x+3}{3} = \frac{2}{3} - x$
44. Solve:  $\frac{3x+2}{7} + \frac{4(x+1)}{5} = \frac{2}{3}(2x+1)$

45. Solve:  $x - \frac{x-1}{2} = 1 - \frac{x-2}{3}$

46. Solve:  $\frac{x}{2} - \frac{1}{5} = \frac{x}{3} + \frac{1}{4}$

47. Solve:  $\frac{x}{2} - \frac{3x}{4} + \frac{5x}{6} = 21$

48. Solve:  $x + 7 - \frac{8x}{3} = \frac{17}{6} - \frac{5x}{2}$

49. Solve:  $\frac{3x+4}{2-6x} = \frac{-2}{5}$

50. Solve:  $\frac{7x+4}{x+2} = \frac{-4}{3}$

51. The ages of Rahul and Haroon are in the ratio 5:7. Four years later the sum of their ages will be 56 years. What are their present ages?
52. Baichung's father is 26 years younger than Baichung's grandfather and 29 years older than Baichung. The sum of the ages of all the three is 135 years. What is the age of each one of them?
53. Lakshmi is a cashier in a bank. She has currency notes of denominations Rs 100, Rs 50 and Rs 10, respectively. The ratio of the number of these notes is 2:3:5. The total cash with Lakshmi is Rs 4,00,000. How many notes of each denomination does she have?
54. I have a total of Rs 300 in coins of denomination Re 1, Rs 2 and Rs 5. The number of Rs 2 coins is 3 times the number of Rs 5 coins. The total number of coins is 160. How many coins of each denomination are with me?
55. The organisers of an essay competition decide that a winner in the competition gets a prize of Rs 100 and a participant who does not win gets a prize of Rs 25. The total prize money distributed is Rs 3,000. Find the number of winners, if the total number of participants is 63.
56. The digits of a two-digit number differ by 3. If the digits are interchanged, and the resulting number is added to the original number, we get 143. What can be the original number?
57. Arjun is twice as old as Shriya. Five years ago his age was three times Shriya's age. Find their present ages.
58. A positive number is 5 times another number. If 21 is added to both the numbers, then one of the new numbers becomes twice the other new number. What are the numbers?

59. Sum of the digits of a two-digit number is 9. When we interchange the digits, it is found that the resulting new number is greater than the original number by 27. What is the two-digit number?
60. One of the two digits of a two digit number is three times the other digit. If you interchange the digits of this two-digit number and add the resulting number to the original number, you get 88. What is the original number?
61. Shobo's mother's present age is six times Shobo's present age. Shobo's age five years from now will be one third of his mother's present age. What are their present ages?
62. There is a narrow rectangular plot, reserved for a school, in Mahuli village. The length and breadth of the plot are in the ratio 11:4. At the rate Rs100 per metre it will cost the village panchayat Rs 75000 to fence the plot. What are the dimensions of the plot?
63. A grandfather is ten times older than his granddaughter. He is also 54 years older than her. Find their present ages.
64. A man's age is three times his son's age. Ten years ago he was five times his son's age. Find their present ages.
65. Present ages of Anu and Raj are in the ratio 4:5. Eight years from now the ratio of their ages will be 5:6. Find their present ages.
- .....

**MCQ WORKSHEET-I**  
**CLASS IX: CHAPTER – 8**  
**QUADRILATERALS**

1. The bisectors of angles of a parallelogram form a :  
(a) trapezium (b) rectangle (c) rhombus (d) kite
2. The angles of a quadrilaterals are in the ratio 3 : 4 : 5 : 6. The respective angles of the quadrilaterals are  
(a)  $60^{\circ}$ ,  $80^{\circ}$ ,  $100^{\circ}$ ,  $120^{\circ}$  (b)  $120^{\circ}$ ,  $100^{\circ}$ ,  $80^{\circ}$ ,  $60^{\circ}$   
(c)  $120^{\circ}$ ,  $60^{\circ}$ ,  $80^{\circ}$ ,  $100^{\circ}$  (d)  $80^{\circ}$ ,  $100^{\circ}$ ,  $120^{\circ}$ ,  $60^{\circ}$ .
3. If diagonals of a quadrilateral are equal and bisect each other at right angles, then it is a:  
(a) parallelogram (b) square (c) rhombus (d) trapezium
4. If in rectangle ABCD, diagonal AC bisects  $\angle A$  as well  $\angle C$ , then ABCD is a:  
(a) parallelogram (b) square (c) rhombus (d) trapezium
5. The line segment joining the midpoints of two sides of a triangle is parallel to the third side and \_\_\_\_\_ of it.  
(a) half (b) one third (c) one fourth (d) equal
6. Line segment joining the mid points of the opposite sides of a quadrilateral \_\_\_\_\_ each other.  
(a) trisect (b) bisect (c) coincide (d) none of these.
7. Three angles of a quadrilateral are  $75^{\circ}$ ,  $90^{\circ}$  and  $75^{\circ}$ . The fourth angle is  
(a)  $90^{\circ}$  (b)  $95^{\circ}$  (c)  $105^{\circ}$  (d)  $120^{\circ}$
8. A diagonal of a rectangle is inclined to one side of the rectangle at  $25^{\circ}$ . The acute angle between the diagonals is  
(a)  $55^{\circ}$  (b)  $50^{\circ}$  (c)  $40^{\circ}$  (d)  $25^{\circ}$
9. ABCD is a rhombus such that  $\angle ACB = 40^{\circ}$ , then  $\angle ADB =$   
(a)  $45^{\circ}$  (b)  $50^{\circ}$  (c)  $40^{\circ}$  (d)  $60^{\circ}$
10. The quadrilateral formed by joining the midpoints of the sides of a quadrilateral PQRS, taken in order, is a rectangle, if  
(a) PQRS is a rectangle (b) PQRS is an parallelogram  
(c) diagonals of PQRS are perpendicular (d) diagonals of PQRS are equal.
11. The quadrilateral formed by joining the midpoints of the sides of a quadrilateral PQRS, taken in order, is a rhombus, if  
(a) PQRS is a rhombus (b) PQRS is an parallelogram  
(c) diagonals of PQRS are perpendicular (d) diagonals of PQRS are equal.
12. If angles A, B, C and D of the quadrilateral ABCD, taken in order are in the ratio 3:7:6:4, then ABCD is a  
(a) parallelogram (b) kite (c) rhombus (d) trapezium

**MCQ WORKSHEET-II**  
**CLASS IX: CHAPTER – 8**  
**QUADRILATERALS**

1. If bisectors of  $\angle A$  and  $\angle B$  of a quadrilateral ABCD intersect each other at P, of  $\angle B$  and  $\angle C$  at Q, of  $\angle C$  and  $\angle D$  at R and of  $\angle D$  and  $\angle A$  at S, then PQRS is a  
(a) parallelogram (b) rectangle (c) rhombus  
(d) quadrilateral whose opposite angles are supplementary.
2. If APB and CQD are two parallel lines then bisectors of the angles APQ, BPQ, CQP and PQD form a  
(a) parallelogram (b) square (c) rhombus (d) rectangle
3. The figure obtained the midpoints of the sides of the sides of a rhombus, taken in order is a  
(a) parallelogram (b) square (c) rhombus (d) rectangle
4. D and E are the midpoints of the sides AB and AC of  $\triangle ABC$  and O is any point on side BC. O is joined to A. If P and Q are the midpoints of OB and OC respectively, then DEQP is a  
(a) parallelogram (b) square (c) rhombus (d) rectangle
5. The quadrilateral formed by joining the midpoints of the sides of a quadrilateral PQRS, taken in order, is a square only if  
(a) PQRS is a rhombus (b) diagonals of PQRS are equal and perpendicular  
(c) diagonals of PQRS are perpendicular (d) diagonals of PQRS are equal.
6. The diagonals AC and BD of a parallelogram ABCD intersect each other at the point O. If  $\angle DAC = 32^\circ$  and  $\angle AOB = 70^\circ$ , then  $\angle DBC$  is equal to  
(a)  $24^\circ$  (b)  $86^\circ$  (c)  $38^\circ$  (d)  $32^\circ$
7. Which of the following is not true for a parallelogram?  
(a) opposite sides are equal (b) opposite angles are bisected by the diagonals  
(c) opposite angles are equal (d) diagonals bisect each other.
8. D and E are the midpoints of the sides AB and AC of  $\triangle ABC$ . DE is produced to F. To prove that CF is equal and parallel to DA, we need an additional information which is  
(a)  $\angle DAE = \angle EFC$  (b)  $AE = EF$  (c)  $DE = EF$  (d)  $\angle ADE = \angle ECF$
9. The bisectors of any two adjacent angles of a parallelogram intersect at  
(a)  $45^\circ$  (b)  $30^\circ$  (c)  $90^\circ$  (d)  $60^\circ$
10. The bisectors of the angles of a parallelogram enclose a  
(a) parallelogram (b) square (c) rhombus (d) rectangle
11. ABCD is a parallelogram and E and F are the centroid of triangle ABD and BCD respectively, then EF =  
(a) AE (b) BE (c) CE (d) DE
12. ABCD is a parallelogram, M is the midpoint of BD and BM bisects  $\angle B$ , then  $\angle AMB =$   
(a)  $45^\circ$  (b)  $75^\circ$  (c)  $90^\circ$  (d)  $60^\circ$

**MCQ WORKSHEET-III**  
**CLASS IX: CHAPTER – 8**  
**QUADRILATERALS**

1. Given four points A, B, C, D such that three points A, B, C are collinear. By joining these points in order, we get  
(a) a straight line (b) a triangle (c) quadrilateral (d) none of these
2. In quadrilateral ABCD,  $AB = BC$  and  $CD = DA$ , then the quadrilateral is a  
(a) parallelogram (b) rhombus (c) kite (d) trapezium
3. Given a triangular prism, then what can we conclude about the lateral faces.  
(a) faces are rectangular (b) faces are parallelogram  
(c) faces are trapeziums (d) square
4. The bisectors of the angles of parallelogram enclose a  
(a) parallelogram (b) rhombus (c) rectangle (d) square
5. Which if the following quadrilateral a rhombus?  
(a) diagonals bisect each other (b) all the four sides are equal  
(c) diagonals bisect opposite angles (d) one angle between the diagonals is  $60^\circ$ .
6. Consecutive angles of parallelogram are  
(a) equal (b) supplementary (c) complementary (d) none of these
7. Given a rectangle ABCD and P, Q, R, S midpoints of AB, BC, CD and DA respectively. Length of diagonal of rectangle is 8 cm, the quadrilateral PQRS is  
(a) parallelogram with adjacent sides 4 cm (b) rectangle with adjacent sides 4 cm  
(c) rhombus with side 4 cm (d) square with side 4 cm
8. In parallelogram ABCD, bisectors of angles A and B intersect each other at O. The value of  $\angle AOB$  is:  
(a)  $30^\circ$  (b)  $60^\circ$  (c)  $90^\circ$  (d)  $120^\circ$

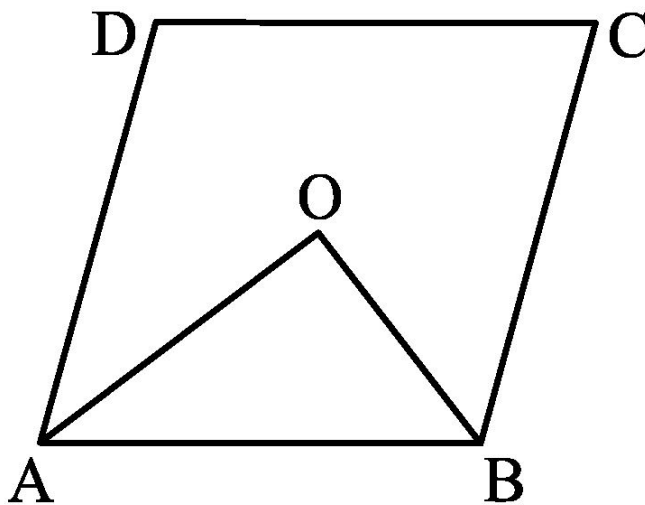

9. If an angle of a parallelogram is two-third of its adjacent angle, the smallest angle of the parallelogram is  
(a)  $108^\circ$  (b)  $54^\circ$  (c)  $72^\circ$  (d)  $81^\circ$

10. If the degree measures of the angles of quadrilateral are  $4x$ ,  $7x$ ,  $9x$  and  $10x$ , what is the sum of the measures of the smallest angle and largest angle?

- (a)  $140^\circ$  (b)  $150^\circ$  (c)  $168^\circ$  (d)  $180^\circ$

11. In the given figure ABCD is a parallelogram, what is the sum of the angle  $x$ ,  $y$  and  $z$ ?

- (a)  $140^\circ$  (b)  $150^\circ$  (c)  $168^\circ$  (d)  $180^\circ$

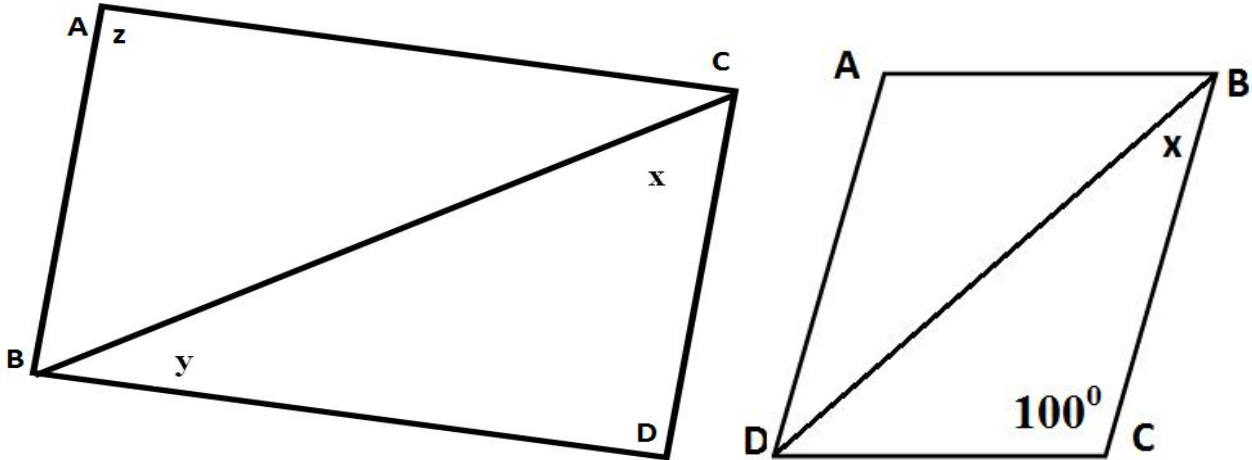

12. In the above figure ABCD is a rhombus, then the value of  $x$  is

- (a)  $40^\circ$  (b)  $50^\circ$  (c)  $60^\circ$  (d)  $80^\circ$

13. In the below figure ABCD is a rhombus, then the value of  $x$  is

- (a)  $20^\circ$  (b)  $25^\circ$  (c)  $30^\circ$  (d)  $50^\circ$

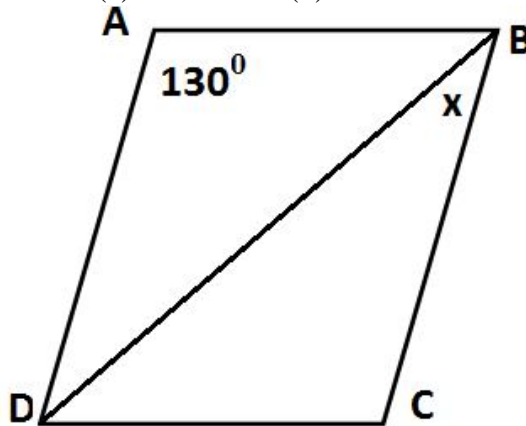

14. ABCD is a parallelogram and  $AB = 12\text{cm}$ ,  $AD = 8\text{ cm}$  then perimeter of parallelogram ABCD is

- (a) 20 cm (b) 40 cm (c) 60 cm (d) 80 cm

15. In parallelogram CARS,  $m\angle C = 5x - 20$  and  $m\angle A = 3x + 40$ . Find the value of  $x$ .

- (a) 15 (b) 20 (c) 30 (d) 130

**MCQ WORKSHEET-IV**  
**CLASS IX: CHAPTER – 8**  
**QUADRILATERALS**

1. If two consecutive sides of a rhombus are represented by  $3x - 6$  and  $x + 14$ , then the perimeter of the rhombus is  
(a) 10            (b) 24            (c) 70            (d) 96

2. Points  $A, B, C,$  and  $D$  are midpoints of the sides of square  $JETS$ . If the area of  $JETS$  is 36, the area of  $ABCD$  is  
(a)  $9\sqrt{2}$     (b)  $18\sqrt{2}$     (c) 9    (d) 18

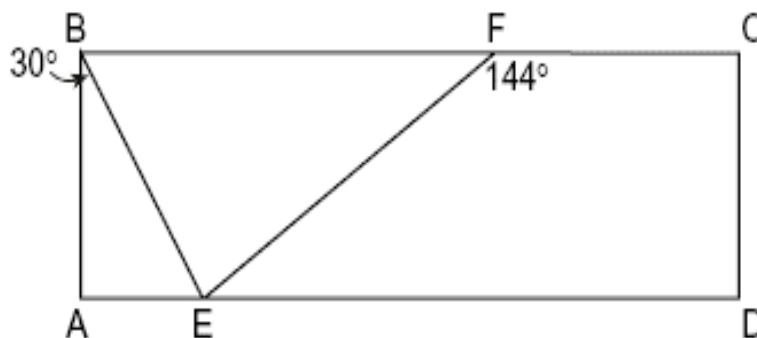
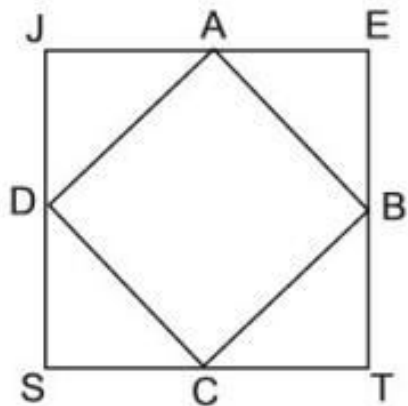

3. In the accompanying above diagram of rectangle  $ABCD$ ,  $m\angle ABE = 30$  and  $m\angle CFE = 144$ . Find  $m\angle BEF$ .  
(a)  $36^\circ$             (b)  $60^\circ$             (c)  $84^\circ$             (d)  $90^\circ$
4. A quadrilateral must be a parallelogram if one pair of opposite sides is  
(a) congruent, only.    (b) parallel and the other pair of opposite sides is congruent.  
(c) congruent and parallel.    (d) parallel only
5. The perimeter of a rhombus is 60. If the length of its longer diagonal measures 24, the length of the shorter diagonal is  
(a) 20            (b) 18            (c) 15            (d) 9
6. Find the perimeter of a rhombus whose diagonals measure 12 and 16.  
(a) 10            (b) 20            (c) 40            (d) 80
7. Which statement is true about all parallelograms?  
(a) The diagonals are congruent.  
(b) The area is the product of two adjacent sides.  
(c) The opposite angles are congruent.  
(d) The diagonals are perpendicular to each other.
8. Which property is true for all trapezoids?  
(a) Only two opposite sides are parallel.  
(b) Consecutive angles are supplementary.  
(c) The base angles are congruent.  
(d) All angles are equal.



9. In the diagram at the right,  $ABCD$  is a square, diagonal  $BD$  is extended through  $D$  to  $E$ .  $AD = DE$  and  $AE$  is drawn as given in figure. What is  $m\angle DAE$  ?  
 (a) 22.5      (b) 45.0      (c) 112.5      (d) 135.0

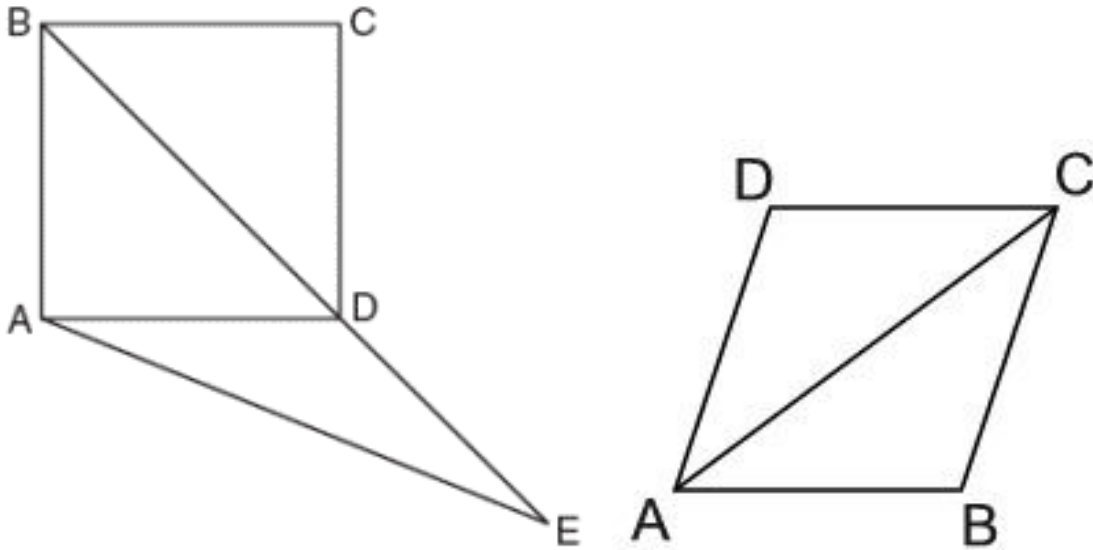

10. In the above right sided diagram of rhombus  $ABCD$ ,  $m\angle CAB = 35^\circ$ . Find  $m\angle CDA$ .  
 (a)  $35^\circ$       (b)  $70^\circ$       (c)  $110^\circ$       (d)  $140^\circ$
11. In rectangle  $DATE$ , diagonals  $DT$  and  $AE$  intersect at  $S$ . If  $AE = 40$  and  $ST = x + 5$ , find the value of  $x$ .  
 (a) 10      (b) 18      (c) 15      (d) 20
12. A parallelogram must be a rectangle if its diagonals  
 (a) bisect each other.  
 (b) bisect the angles to which they are drawn.  
 (c) are perpendicular to each other.  
 (d) are congruent.



**MCQ WORKSHEET-V**  
**CLASS IX: CHAPTER – 8**  
**QUADRILATERALS**

1. Three angles of a quadrilateral are  $75^{\circ}$ ,  $90^{\circ}$  and  $75^{\circ}$ . The fourth angle is  
(A)  $90^{\circ}$  (B)  $95^{\circ}$  (C)  $105^{\circ}$  (D)  $120^{\circ}$
2. A diagonal of a rectangle is inclined to one side of the rectangle at  $25^{\circ}$ . The acute angle between the diagonals is  
(A)  $55^{\circ}$  (B)  $50^{\circ}$  (C)  $40^{\circ}$  (D)  $25^{\circ}$
3. ABCD is a rhombus such that  $\angle ACB = 40^{\circ}$ . Then  $\angle ADB$  is  
(A)  $40^{\circ}$  (B)  $45^{\circ}$  (C)  $50^{\circ}$  (D)  $60^{\circ}$
4. The quadrilateral formed by joining the mid-points of the sides of a quadrilateral PQRS, taken in order, is a rectangle, if  
(A) PQRS is a rectangle  
(B) PQRS is a parallelogram  
(C) diagonals of PQRS are perpendicular  
(D) diagonals of PQRS are equal.
5. The quadrilateral formed by joining the mid-points of the sides of a quadrilateral PQRS, taken in order, is a rhombus, if  
(A) PQRS is a rhombus  
(B) PQRS is a parallelogram  
(C) diagonals of PQRS are perpendicular  
(D) diagonals of PQRS are equal.
6. If angles A, B, C and D of the quadrilateral ABCD, taken in order, are in the ratio 3:7:6:4, then ABCD is a  
(A) rhombus (B) parallelogram  
(C) trapezium (D) kite
7. If bisectors of  $\angle A$  and  $\angle B$  of a quadrilateral ABCD intersect each other at P, of  $\angle B$  and  $\angle C$  at Q, of  $\angle C$  and  $\angle D$  at R and of  $\angle D$  and  $\angle A$  at S, then PQRS is a  
(A) rectangle (B) rhombus (C) parallelogram  
(D) quadrilateral whose opposite angles are supplementary
8. If APB and CQD are two parallel lines, then the bisectors of the angles APQ, BPQ, CQP and PQD form  
(A) a square (B) a rhombus  
(C) a rectangle (D) any other parallelogram
9. The figure obtained by joining the mid-points of the sides of a rhombus, taken in order, is  
(A) a rhombus (B) a rectangle  
(C) a square (D) any parallelogram
10. D and E are the mid-points of the sides AB and AC of  $\triangle ABC$  and O is any point on side BC. O is joined to A. If P and Q are the mid-points of OB and OC respectively, then DEQP is  
(A) a square (B) a rectangle  
(C) a rhombus (D) a parallelogram

11. The figure formed by joining the mid-points of the sides of a quadrilateral ABCD, taken in order, is a square only if,
- (A) ABCD is a rhombus
  - (B) diagonals of ABCD are equal
  - (C) diagonals of ABCD are equal and perpendicular
  - (D) diagonals of ABCD are perpendicular.
12. The diagonals AC and BD of a parallelogram ABCD intersect each other at the point O. If  $\angle DAC = 32^\circ$  and  $\angle AOB = 70^\circ$ , then  $\angle DBC$  is equal to  
(A)  $24^\circ$  (B)  $86^\circ$  (C)  $38^\circ$  (D)  $32^\circ$
13. D and E are the mid-points of the sides AB and AC respectively of  $\triangle ABC$ . DE is produced to F. To prove that CF is equal and parallel to DA, we need an additional information which is
- (A)  $\angle DAE = \angle EFC$
  - (B)  $AE = EF$
  - (C)  $DE = EF$
  - (D)  $\angle ADE = \angle ECF$ .
14. Which of the following is not true for a parallelogram?
- (A) opposite sides are equal
  - (B) opposite angles are equal
  - (C) opposite angles are bisected by the diagonals
  - (D) diagonals bisect each other.
- .....

**PRACTICE QUESTIONS**  
**CLASS IX: CHAPTER – 8**  
**QUADRILATERALS**

1. In the below figure, bisectors of  $\angle B$  and  $\angle D$  of quadrilateral ABCD meet CD and AB, produced at P and Q respectively. Prove that  $\angle P + \angle Q = \frac{1}{2} (\angle ABC + \angle ADC)$

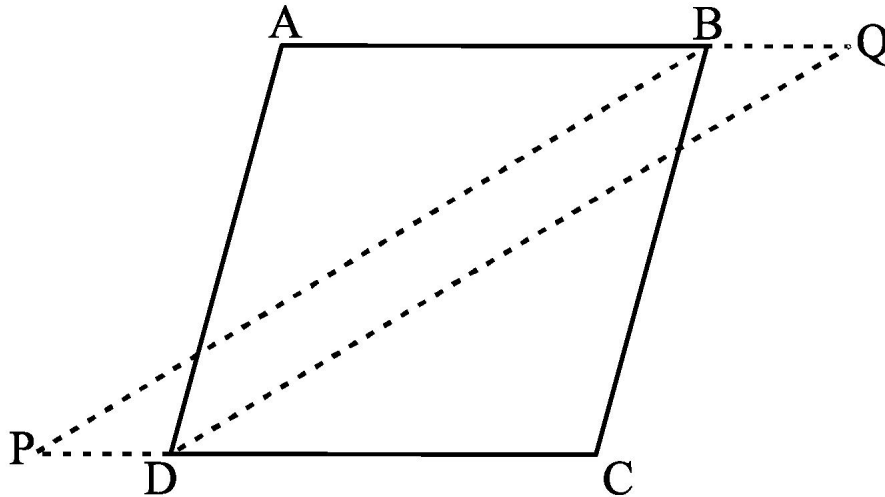

2. In  $\triangle ABC$ , AD is the median through A and E is the midpoint of AD. BE produced meets AC in F such that  $BF \parallel DK$ . Prove that  $AF = \frac{1}{3} AC$

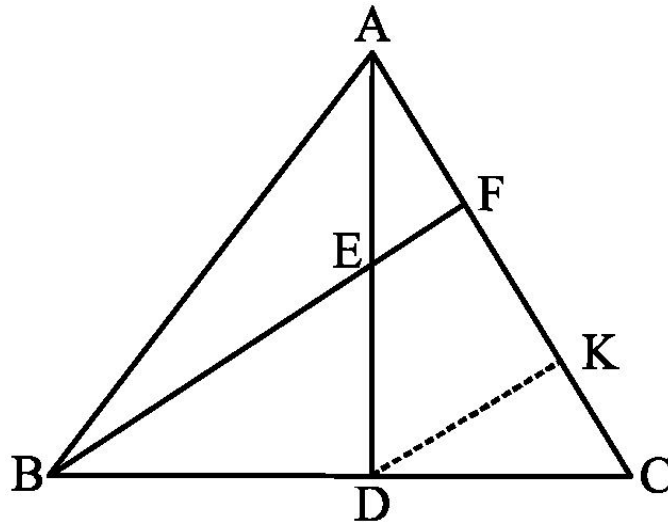

3. In a parallelogram, the bisectors of any two consecutive angles intersect at right angle. Prove it.
4. In a quadrilateral ABCD, AO and BO are the bisectors of  $\angle A$  and  $\angle B$  respectively. Prove that  $\angle AOB = \frac{1}{2} (\angle C + \angle D)$
5. ABCD is a square E, F, G, H are points on AB, BC, CD and DA respectively such that  $AE = BF = CG = DH$ . Prove that EFGH is a square.
6. ABCD is a parallelogram. If its diagonals are equal, then find the value of  $\angle ABC$ .

7. In the below figure, ABCD is a parallelogram and  $\angle DAB = 60^\circ$ . If the bisector AP and BP of angles A and B respectively meet P on CD. Prove that P is the midpoint of CD.

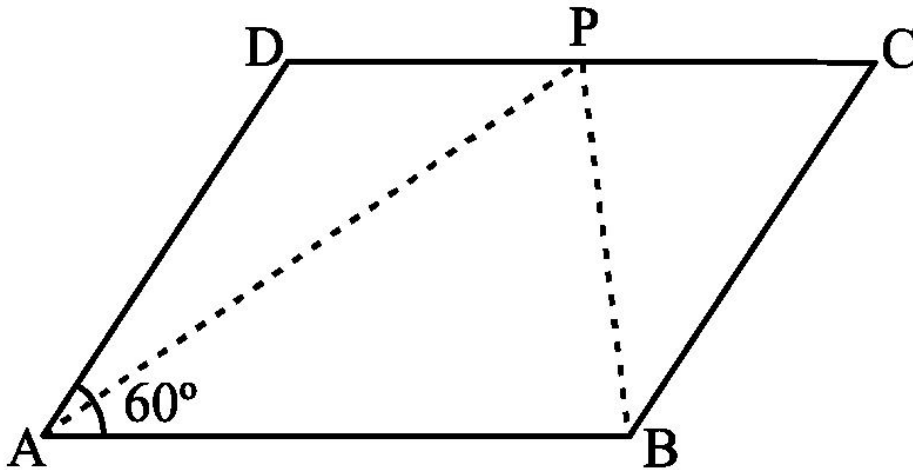

8. In the below given figure, ABCD is a parallelogram and E is the midpoint of side BC, DE and AB when produced meet at F. Prove that  $AF = 2AB$ .

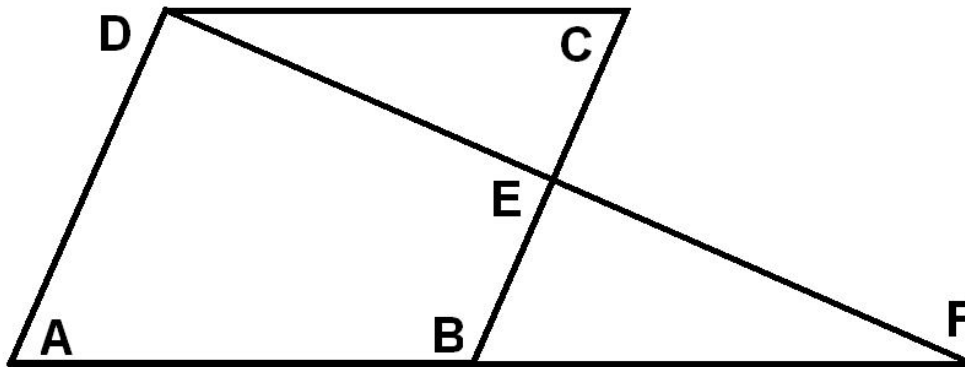

9.  $\triangle ABC$  is right angle at B and P is the midpoint of AC and Q is any point on AB. Prove that (i)  $PQ \perp AB$  (ii) Q is the midpoint of AB (iii)  $PA = \frac{1}{2} AC$
10. The diagonals of a parallelogram ABCD intersect at O. A line through O intersects AB at X and DC at Y. Prove that  $OX = OY$ .
11. ABCD is a parallelogram. AB is produced to E so that  $BE = AB$ . Prove that ED bisects BC.
12. If ABCD is a quadrilateral in which  $AB \parallel CD$  and  $AD = BC$ , prove that  $\angle A = \angle B$ .
13. Diagonals AC and BD of a parallelogram ABCD intersect each other at O. If  $OA = 3$  cm and  $OD = 2$  cm, determine the lengths of AC and BD.
14. In quadrilateral ABCD,  $\angle A + \angle D = 180^\circ$ . What special name can be given to this quadrilateral?
15. All the angles of a quadrilateral are equal. What special name is given to this quadrilateral?
16. In  $\triangle ABC$ ,  $AB = 5$  cm,  $BC = 8$  cm and  $CA = 7$  cm. If D and E are respectively the mid-points of AB and BC, determine the length of DE.
17. Diagonals of a quadrilateral ABCD bisect each other. If  $\angle A = 35^\circ$ , determine  $\angle B$ .

18. Opposite angles of a quadrilateral ABCD are equal. If  $AB = 4$  cm, determine CD.

19. In the below figure, it is given that BDEF and FDCE are parallelograms. Can you say that  $BD = CD$ ? Why or why not?

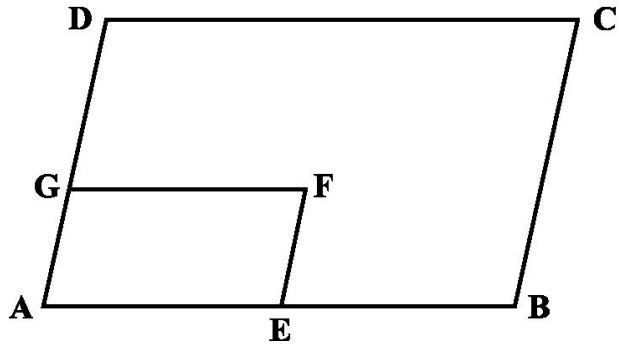
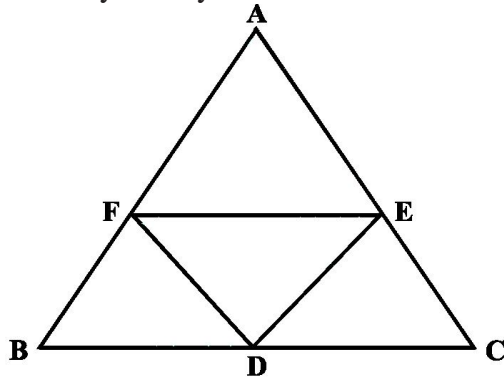

20. In the above right sided figure, ABCD and AEGF are two parallelograms. If  $\angle C = 55^\circ$ , determine  $\angle F$ .

21. Angles of a quadrilateral are in the ratio  $3 : 4 : 4 : 7$ . Find all the angles of the quadrilateral.

22. In the below figure, X and Y are respectively the mid-points of the opposite sides AD and BC of a parallelogram ABCD. Also, BX and DY intersect AC at P and Q, respectively. Show that  $AP = PQ = QC$ .

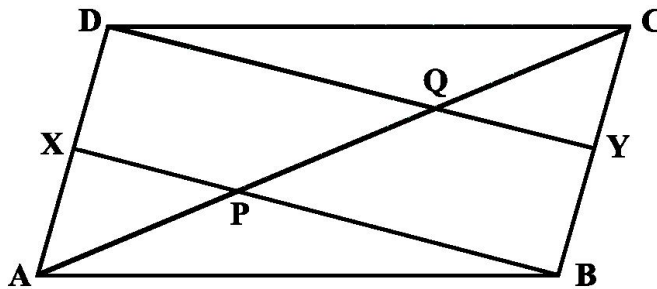

23. One angle of a quadrilateral is of  $108^\circ$  and the remaining three angles are equal. Find each of the three equal angles.

24. ABCD is a trapezium in which  $AB \parallel DC$  and  $\angle A = \angle B = 45^\circ$ . Find angles C and D of the trapezium.

25. The angle between two altitudes of a parallelogram through the vertex of an obtuse angle of the parallelogram is  $60^\circ$ . Find the angles of the parallelogram.

26. ABCD is a rhombus in which altitude from D to side AB bisects AB. Find the angles of the rhombus.

27. E and F are points on diagonal AC of a parallelogram ABCD such that  $AE = CF$ . Show that BFDE is a parallelogram.

28. ABCD is a parallelogram and  $\angle DAB = 60^\circ$ . If the bisectors AP and BP of angles A and B respectively, meet at P on CD, prove that P is the midpoint of CD.

29. ABCD is a parallelogram. AM and BN are respectively, the perpendiculars from A and B to DC and CD produced. Prove that  $AM = BN$ .

30. ABCD is a parallelogram. L and M are points on AB and DC respectively and  $AL = CM$ . Prove that LM and BD bisect each other.

31. Points P and Q have been taken on opposite sides AB and CD, respectively of a parallelogram ABCD such that  $AP = CQ$  (see below figure). Show that AC and PQ bisect each other.

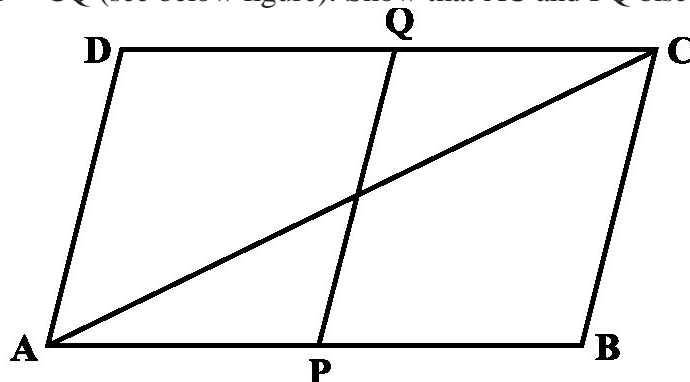

32. In the below figure, P is the mid-point of side BC of a parallelogram ABCD such that  $\angle BAP = \angle DAP$ . Prove that  $AD = 2CD$ .

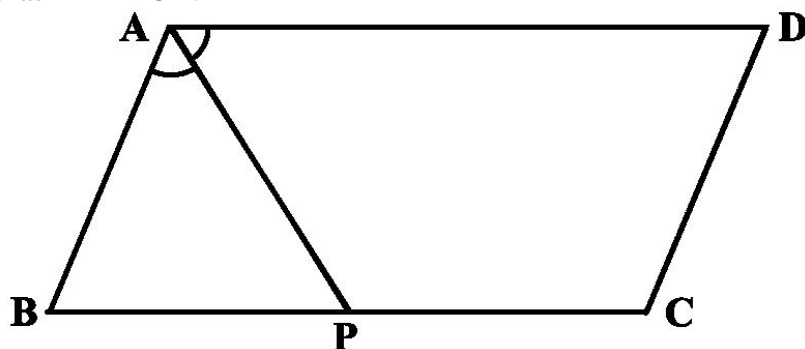

33. D, E and F are the mid-points of the sides BC, CA and AB, respectively of an equilateral triangle ABC. Show that  $\triangle DEF$  is also an equilateral triangle.

34. E is the mid-point of the side AD of the trapezium ABCD with  $AB \parallel DC$ . A line through E drawn parallel to AB intersect BC at F. Show that F is the mid-point of BC.

35. PQ and RS are two equal and parallel line-segments. Any point M not lying on PQ or RS is joined to Q and S and lines through P parallel to QM and through R parallel to SM meet at N. Prove that line segments MN and PQ are equal and parallel to each other.

36. Prove that “If the diagonals of a quadrilateral bisect each other, then it is a parallelogram”.

37. Prove that “A quadrilateral is a parallelogram if a pair of opposite sides is equal and parallel”.

38. Prove that “A quadrilateral is a parallelogram if its opposite angles are equal”.

39. Show that the diagonals of a rhombus are perpendicular to each other.

40. Two parallel lines  $l$  and  $m$  are intersected by a transversal  $p$ . Show that the quadrilateral formed by the bisectors of interior angles is a rectangle.

41. Show that the bisectors of angles of a parallelogram form a rectangle.

42. If the diagonals of a parallelogram are equal, then show that it is a rectangle.

43. Show that if the diagonals of a quadrilateral bisect each other at right angles, then it is a rhombus.

44. Show that the diagonals of a square are equal and bisect each other at right angles.
45. Show that if the diagonals of a quadrilateral are equal and bisect each other at right angles, then it is a square.
46. In the adjoining figure, ABCD is a parallelogram in which P and Q are mid-points of opposite sides AB and CD. If AQ intersects DP at S and BQ intersects CP at R, show that:
- APCQ is a parallelogram.
  - DPBQ is a parallelogram.
  - PSQR is a parallelogram.

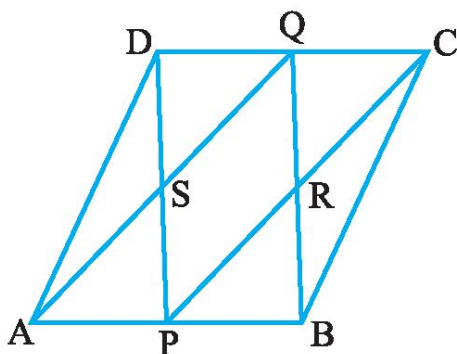

47. The angles of quadrilateral are in the ratio 3 : 5 : 9 : 13. Find all the angles of the quadrilateral.
48. Prove that “The line segment joining the mid-points of two sides of a triangle is parallel to the third side and half of it”.
49. Prove that “The line drawn through the mid-point of one side of a triangle, parallel to another side bisects the third side”.
50. Show that if the diagonals of a quadrilateral are equal and bisect each other at right angles, then it is a square.
51. ABCD is a rhombus and P, Q, R and S are the mid-points of the sides AB, BC, CD and DA respectively. Show that the quadrilateral PQRS is a rectangle.
52. ABC is a triangle right angled at C. A line through the mid-point M of hypotenuse AB and parallel to BC intersects AC at D. Show that
- D is the mid-point of AC
  - $MD \perp AC$
  - $CM = MA = \frac{1}{2} AB$
53. In  $\triangle ABC$ , D, E and F are respectively the mid-points of sides AB, BC and CA. Show that  $\triangle ABC$  is divided into four congruent triangles by joining D, E and F.

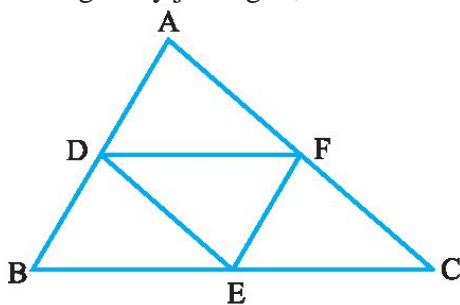

54. Prove that the quadrilateral formed by joining the mid-points of the sides of a quadrilateral, in order, is a parallelogram.



55.  $l$ ,  $m$  and  $n$  are three parallel lines intersected by transversals  $p$  and  $q$  such that  $l$ ,  $m$  and  $n$  cut off equal intercepts  $AB$  and  $BC$  on  $p$ . Show that  $l$ ,  $m$  and  $n$  cut off equal intercepts  $DE$  and  $EF$  on  $q$ .
56. In parallelogram  $ABCD$ , two points  $P$  and  $Q$  are taken on diagonal  $BD$  such that  $DP = BQ$ . Show that:  $APCQ$  is a parallelogram

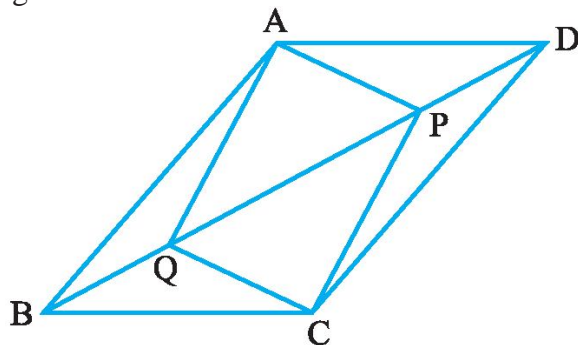

57. In the below figure,  $AB \parallel DE$ ,  $AB = DE$ ,  $AC \parallel DF$  and  $AC = DF$ . Prove that  $BC \parallel EF$  and  $BC = EF$ .

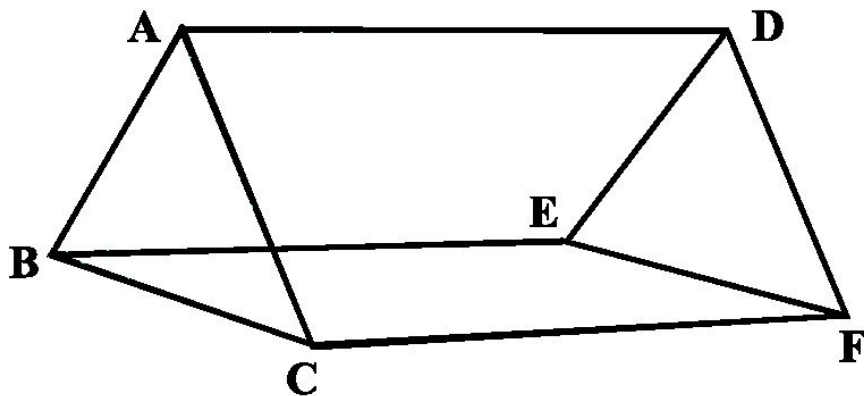

58. A square is inscribed in an isosceles right triangle so that the square and the triangle have one angle common. Show that the vertex of the square opposite the vertex of the common angle bisects the hypotenuse.
59.  $ABCD$  is a rectangle and  $P$ ,  $Q$ ,  $R$  and  $S$  are mid-points of the sides  $AB$ ,  $BC$ ,  $CD$  and  $DA$  respectively. Show that the quadrilateral  $PQRS$  is a rhombus.
60. Show that the line segments joining the mid-points of the opposite sides of a quadrilateral bisect each other.
61.  $E$  and  $F$  are respectively the mid-points of the non-parallel sides  $AD$  and  $BC$  of a trapezium  $ABCD$ . Prove that  $EF \parallel AB$  and  $EF = \frac{1}{2}(AB + CD)$
62. Prove that the quadrilateral formed by the bisectors of the angles of a parallelogram is a rectangle.
63.  $P$  and  $Q$  are points on opposite sides  $AD$  and  $BC$  of a parallelogram  $ABCD$  such that  $PQ$  passes through the point of intersection  $O$  of its diagonals  $AC$  and  $BD$ . Show that  $PQ$  is bisected at  $O$ .
64.  $ABCD$  is a rectangle in which diagonal  $BD$  bisects  $\angle B$ . Show that  $ABCD$  is a square.
65.  $D$ ,  $E$  and  $F$  are respectively the mid-points of the sides  $AB$ ,  $BC$  and  $CA$  of a triangle  $ABC$ . Prove that by joining these mid-points  $D$ ,  $E$  and  $F$ , the triangle  $ABC$  is divided into four congruent triangles.

66. Prove that the line joining the mid-points of the diagonals of a trapezium is parallel to the parallel sides of the trapezium.
67. P is the mid-point of the side CD of a parallelogram ABCD. A line through C parallel to PA intersects AB at Q and DA produced at R. Prove that DA = AR and CQ = QR.
68. E is the mid-point of a median AD of  $\triangle ABC$  and BE is produced to meet AC at F. Show that  $AF = \frac{1}{3} AC$
69. Show that the quadrilateral formed by joining the mid-points of the consecutive sides of a square is also a square.
70. In a parallelogram ABCD, AB = 10 cm and AD = 6 cm. The bisector of  $\angle A$  meets DC in E. AE and BC produced meet at F. Find the length of CF.
71. P, Q, R and S are respectively the mid-points of the sides AB, BC, CD and DA of a quadrilateral ABCD in which AC = BD. Prove that PQRS is a rhombus.
72. P, Q, R and S are respectively the mid-points of the sides AB, BC, CD and DA of a quadrilateral ABCD such that  $AC \perp BD$ . Prove that PQRS is a rectangle.
73. P, Q, R and S are respectively the mid-points of sides AB, BC, CD and DA of quadrilateral ABCD in which AC = BD and  $AC \perp BD$ . Prove that PQRS is a square.
74. A diagonal of a parallelogram bisects one of its angles. Show that it is a rhombus. P and Q are the mid-points of the opposite sides AB and CD of a parallelogram
75. In quadrilateral ABCD. AQ intersects DP at S and BQ intersects CP at R. Show that PRQS is a parallelogram.
76. ABCD is a quadrilateral in which  $AB \parallel DC$  and  $AD = BC$ . Prove that  $\angle A = \angle B$  and  $\angle C = \angle D$ .
77. ABC is a triangle. D is a point on AB such that  $AD = \frac{1}{4} AB$  and E is a point on AC such that  $AE = \frac{1}{4} AC$ . Prove that  $DE = \frac{1}{4} BC$ .
78. Let ABC be an isosceles triangle in which  $AB = AC$ . If D, E, F be the midpoints of the sides BC, CA and AB respectively, show that the segment AD and EF bisect each other at right angles.
79. Prove that the line segment joining the mid-points of the diagonals of a trapezium is parallel to each of the parallel sides and is equal to half the difference of these sides.
80. P is the midpoint of side AB of a parallelogram ABCD. A line through B parallel to PD meets DC at Q and AD produced at R. Prove that (i)  $AR = 2BC$  (ii)  $BR = 2BQ$ .

**MCQ WORKSHEET-I**  
**CLASS IX: CHAPTER – 9**  
**AREAS OF ||<sup>gms</sup> AND TRIANGLES**

1. Parallelograms on the same base and between the same parallels are \_\_\_\_\_ in area.  
 (a) half (b) one third (c) one fourth (d) equal
2. If a triangle and a parallelogram are on the same base and between the same parallels, then prove that the area of the triangle is \_\_\_\_\_ of the area of the parallelogram.  
 (a) half (b) one third (c) one fourth (d) equal
3. In the below Fig., ABCD is a parallelogram,  $AE \perp DC$  and  $CF \perp AD$ . If  $AB = 16$  cm,  $AE = 8$  cm and  $CF = 10$  cm, find AD.  
 (a) 10.8 (b) 11.8 (c) 12.8 (d) 13.8

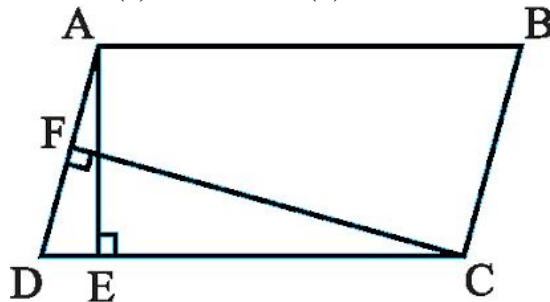

4. In the above Fig., ABCD is a parallelogram,  $AE \perp DC$  and  $CF \perp AD$ . If  $AD = 9$  cm,  $CF = 4$  cm and  $DC = 12$  cm, find AE.  
 (a) 3 cm (b) 6 cm (c) 9 cm (d) 2 cm
5. In the above Fig., ABCD is a parallelogram,  $AE \perp DC$  and  $CF \perp AD$ . If  $AD = 5$  cm,  $CF = 8$  cm and  $AE = 4$  cm, find AB.  
 (a) 10 cm (b) 20 cm (c) 9 cm (d) 12 cm
6. If E, F, G and H are respectively the mid-points of the sides of a parallelogram ABCD, then ar (EFGH) =  
 (a) ar(ABCD) (b)  $\frac{1}{2}$  ar(ABCD) (c)  $\frac{1}{3}$  ar(ABCD) (d)  $\frac{1}{4}$  ar(ABCD)
7. In the below Fig., ABCD is a parallelogram and EFCD is a rectangle, then ar (EFGH) =  
 (a) ar(ABCD) (b)  $\frac{1}{2}$  ar(ABCD) (c)  $\frac{1}{3}$  ar(ABCD) (d)  $\frac{1}{4}$  ar(ABCD)

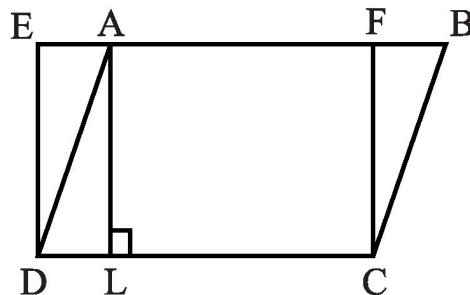

8. Two triangles on the same base (or equal bases) and between the same parallels are \_\_\_\_\_ in area.  
 (a) half (b) one third (c) one fourth (d) equal

9. A median of a triangle divides it into two triangles of \_\_\_\_\_ areas.  
 (a) half (b) one third (c) one fourth (d) equal
10. Area of a triangle is \_\_\_\_\_ the product of its base and the corresponding altitude.  
 (a) half (b) one third (c) one fourth (d) equal
11. Area of a parallelogram is \_\_\_\_\_ the product of its base and the corresponding altitude.  
 (a) half (b) one third (c) one fourth (d) equal
12. The area of a rhombus, the lengths of whose diagonals are 16 cm and 24 cm respectively, is  
 (a)  $192 \text{ cm}^2$  (b)  $120 \text{ cm}^2$  (c)  $384 \text{ cm}^2$  (d) none of these
13. The area of a trapezium whose parallel sides are 9 cm and 6 cm and the distance between these sides is 8 cm is  
 (a)  $92 \text{ cm}^2$  (b)  $120 \text{ cm}^2$  (c)  $60 \text{ cm}^2$  (d) none of these
14. The area of a below quadrilateral is  
 (a)  $112 \text{ cm}^2$  (b)  $120 \text{ cm}^2$  (c)  $114 \text{ cm}^2$  (d) none of these

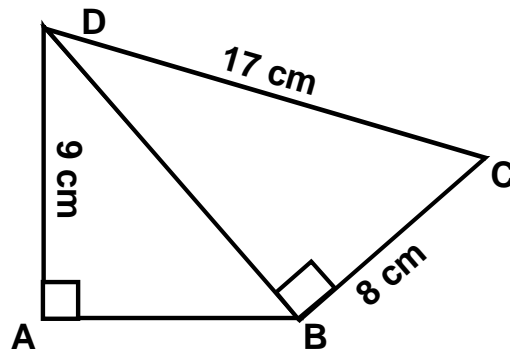

15. The area of a below quadrilateral is  
 (a)  $150 \text{ cm}^2$  (b)  $180 \text{ cm}^2$  (c)  $100 \text{ cm}^2$  (d) none of these

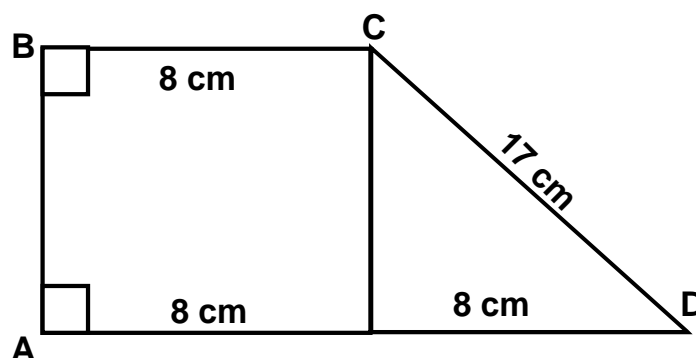

**MCQ WORKSHEET-II**  
**CLASS IX: CHAPTER – 9**  
**AREAS OF ||<sup>gms</sup> AND TRIANGLES**

- D, E and F are respectively the mid-points of the sides BC, CA and AB of a  $\Delta ABC$ , then ar (DEF)
 

(a) ar(ABC)    (b)  $\frac{1}{2}$  ar(ABC)    (c)  $\frac{1}{3}$  ar(ABC)    (d)  $\frac{1}{4}$  ar(ABC)
- D, E and F are respectively the mid-points of the sides BC, CA and AB of a  $\Delta ABC$ , then ar (BDEF)
 

(a) ar(ABC)    (b)  $\frac{1}{2}$  ar(ABC)    (c)  $\frac{1}{3}$  ar(ABC)    (d)  $\frac{1}{4}$  ar(ABC)
- In a triangle ABC, E is the mid-point of median AD, then ar (BED) =
 

(a) ar(ABC)    (b)  $\frac{1}{2}$  ar(ABC)    (c)  $\frac{1}{3}$  ar(ABC)    (d)  $\frac{1}{4}$  ar(ABC)
- In  $\Delta ABC$ , E is any point on median AD then ar (ABE) =
 

(a) ar(ACE)    (b)  $\frac{1}{2}$  ar(ACE)    (c)  $\frac{1}{3}$  ar(ACE)    (d)  $\frac{1}{4}$  ar(ACE)
- ABC and ABD are two triangles on the same base AB. If line- segment CD is bisected by AB at O then ar(ABC) =
 

(a) ar(ABD)    (b)  $\frac{1}{2}$  ar(ABD)    (c)  $\frac{1}{3}$  ar(ABD)    (d)  $\frac{1}{4}$  ar(ABD)
- In Fig. ABCD is a quadrilateral and BE  $\parallel$  AC and also BE meets DC produced at E then the area of  $\Delta ADE$  is \_\_\_\_\_ to the area of the quadrilateral ABCD.
 

(a) half    (b) one third    (c) one fourth    (d) equal

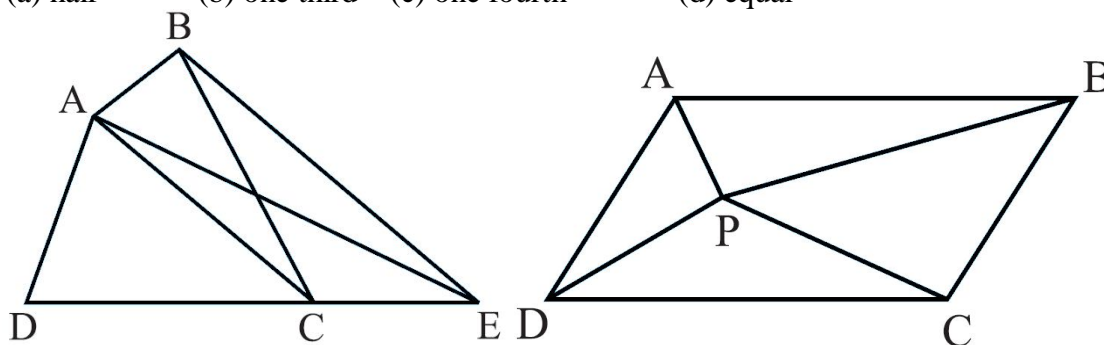

- In the above sided Fig, P is a point in the interior of a parallelogram ABCD then ar (APB) + ar (PCD) =
 

(a) ar(ABCD)    (b)  $\frac{1}{2}$  ar(ABCD)    (c)  $\frac{1}{3}$  ar(ABCD)    (d)  $\frac{1}{4}$  ar(ABCD)
- In Fig, PQRS and ABRS are parallelograms and X is any point on side BR then ar (AX S) =
 

(a) ar(PQRS)    (b)  $\frac{1}{2}$  ar(PQRS)    (c)  $\frac{1}{3}$  ar(PQRS)    (d)  $\frac{1}{4}$  ar(PQRS)
- In Fig, PQRS and ABRS are parallelograms and X is any point on side BR then ar (ABRS) =
 

(a) ar(PQRS)    (b)  $\frac{1}{2}$  ar(PQRS)    (c)  $\frac{1}{3}$  ar(PQRS)    (d)  $\frac{1}{4}$  ar(PQRS)

10. P and Q are any two points lying on the sides DC and AD respectively of a parallelogram ABCD then ar (APB) =

- (a) ar(BQC)    (b)  $\frac{1}{2}$  ar(BQC)    (c)  $\frac{1}{3}$  ar(BQC)    (d)  $\frac{1}{4}$  ar(BQC)

11. In the below figure, ABCD is trapezium in which AB || DC and its diagonals AC and BD intersect at O then ar(AOD) =

- (a) ar(BOC)    (b)  $\frac{1}{2}$  ar(BOC)    (c)  $\frac{1}{3}$  ar(BOC)    (d)  $\frac{1}{4}$  ar(BOC)

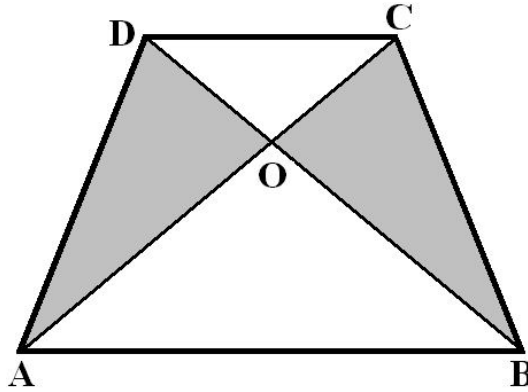

12. In the adjoining figure, ABCD is a quadrilateral in which diagonal BC = 14 cm. If AL ⊥ BD and CM ⊥ BD such that AL = 8cm and CM = 6 cm, then the area of quadrilateral is

- (a) 90 cm<sup>2</sup>    (b) 95 cm<sup>2</sup>    (c) 98 cm<sup>2</sup>    (d) none of these

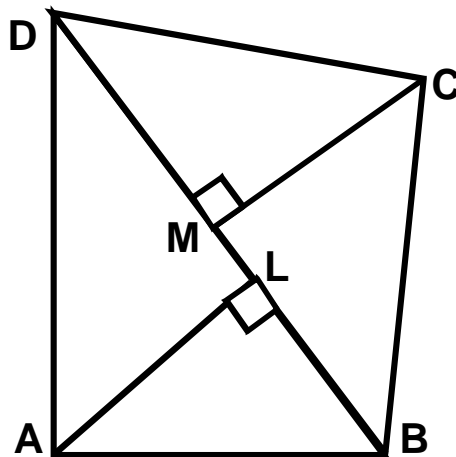

**MCQ WORKSHEET-III**  
**CLASS IX: CHAPTER – 9**  
**AREAS OF  $\parallel$ gms AND TRIANGLES**

1. Given figure A and figure B such that  $\text{area}(A) = 20$  sq. units and  $\text{area}(B) = 20$  sq. units. The  
 (a) figure A and B are congruent (b) figure A and B are all not congruent.  
 (c) figure A and B may or may not be congruent (d) none of these.
2. Out of the given figures, mark which are not on the same base but between same parallels

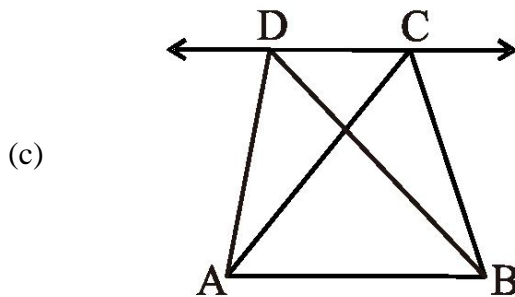
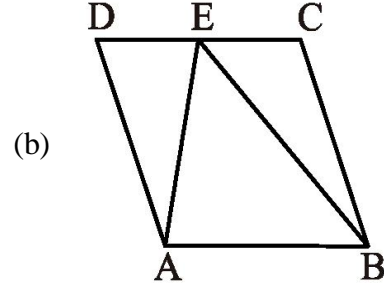
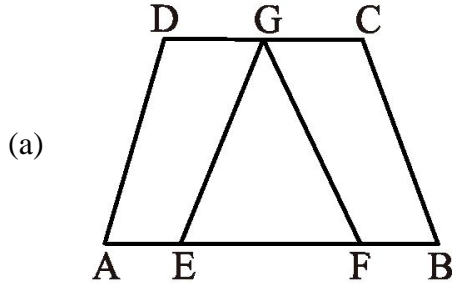

(d) none of these

3. In the given figure,  $BD = DE = EC$ . Mark the correct option

- (a)  $\text{ar}(\triangle ABD) = \text{ar}(\triangle AEC)$   
 (b)  $\text{ar}(\triangle DBA) = \text{ar}(\triangle ADC)$   
 (c)  $\text{ar}(\triangle ADE) = \frac{1}{3} \text{ar}(\triangle ABC)$   
 (d)  $\text{ar}(\triangle ABE) = \frac{2}{3} \text{ar}(\triangle ABC)$

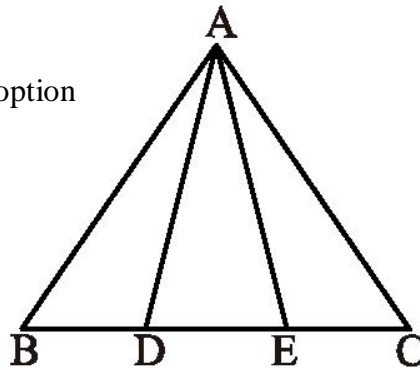

4. ABCDE is a pentagon. A line through B line parallel to AC meet DC produced at F.

- (a)  $\text{ar}(\triangle ACB) = \text{ar}(\triangle AEC)$   
 (b)  $\text{ar}(\triangle ABF) = \text{ar}(\triangle CABF)$   
 (c)  $\text{ar}(\triangle ACF) = \text{ar}(\triangle CBF)$   
 (d)  $\text{ar}(\triangle ABF) = \text{ar}(\triangle ABC)$

5. In the below figure, ABCD is a parallelogram, then  $\text{ar}(\triangle AFB)$  is  
 (a)  $16 \text{ cm}^2$  (b)  $8 \text{ cm}^2$  (c)  $4 \text{ cm}^2$  (d)  $2 \text{ cm}^2$

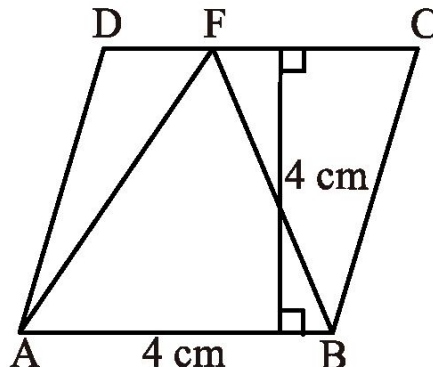

6. In the given figure, ABCD and ABFE are parallelograms and  $\text{ar}(\text{quad. EABC}) = 17 \text{ cm}^2$ ,  $\text{ar}(\text{parallelogram ABCD}) = 25 \text{ cm}^2$  then  $\text{ar}(\triangle BCF)$  is  
 (a)  $4 \text{ cm}^2$       (b)  $8 \text{ cm}^2$       (c)  $4.8 \text{ cm}^2$       (d)  $6 \text{ cm}^2$

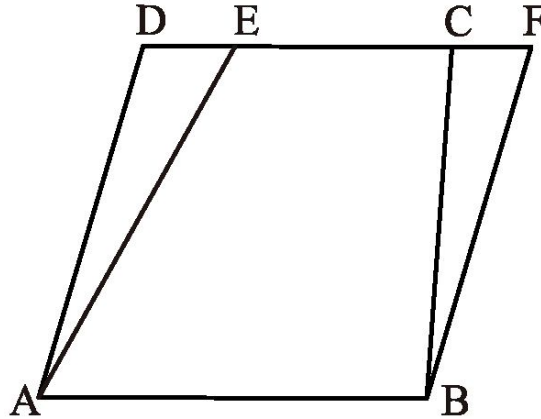

7. Given  $\text{ar}(\triangle ABC) = 32 \text{ cm}^2$ , AD is median of  $\triangle ABC$ , and BE is median of  $\triangle ABD$ . If BO is median of  $\triangle ABE$ , the  $\text{ar}(\triangle BOE)$  is  
 (a)  $16 \text{ cm}^2$       (b)  $4 \text{ cm}^2$       (c)  $2 \text{ cm}^2$       (d)  $1 \text{ cm}^2$

8. In the given figure, find x, if ABCD is a rhombus and  $AC = 4 \text{ cm}$ ,  $\text{ar}(\text{ABCD}) = 20 \text{ cm}^2$ .

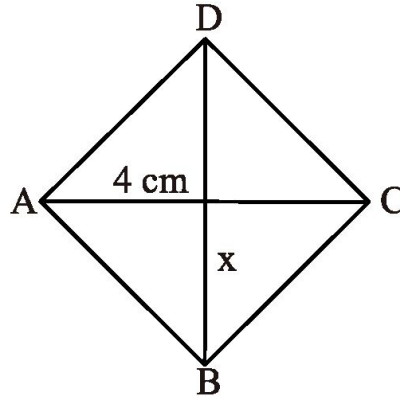

- (a) 4 cm      (b) 5 cm      (c) 10 cm      (d) 2.5 cm

9. In the given figure, find the area of rhombus ABCD if  $AO = 4 \text{ cm}$  and  $OD = 5 \text{ cm}$ .

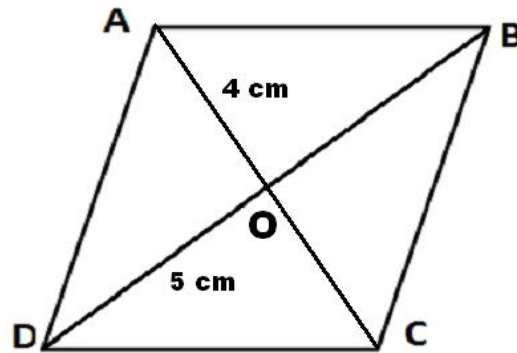

- A.  $40 \text{ cm}^2$       B.  $80 \text{ cm}^2$       C.  $20 \text{ cm}^2$       D.  $10 \text{ cm}^2$

10. The area of rhombus is  $120 \text{ cm}^2$  and one of its diagonals is 12 cm then the other diagonal is  
 A. 5 cm      B. 10 cm      C. 20 cm      D. 12 cm

11. Given in triangle ABC, BE is the median of  $\triangle ABC$  and  $\text{ar}(\triangle ABE) = 20 \text{ cm}^2$ , then  $\text{ar}(\triangle ABC) =$   
 A.  $40 \text{ cm}^2$       B.  $80 \text{ cm}^2$       C.  $20 \text{ cm}^2$       D.  $10 \text{ cm}^2$



12. In the adjoining figure, ABCD is a trapezium in which  $AB \parallel DC$ ;  $AB = 7$  cm;  $AD = BC = 5$  cm and the distance between the parallel lines is 4 cm, then length DC =

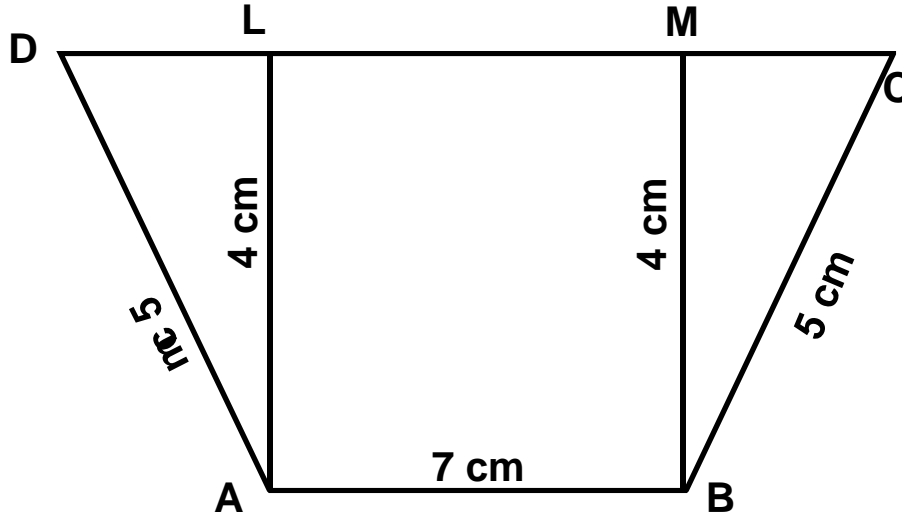

- A. 15 cm                      B. 13 cm                      C. 11 cm                      D. 12 cm

13. In the above figure, ABCD is a trapezium in which  $AB \parallel DC$ ;  $AB = 7$  cm;  $AD = BC = 5$  cm and the distance between the parallel lines is 4 cm, then the area of trap. ABCD =

- A.  $40 \text{ cm}^2$                       B.  $80 \text{ cm}^2$                       C.  $20 \text{ cm}^2$                       D.  $10 \text{ cm}^2$

14. In the below figure, ABCD is a parallelogram;  $DC = 5$  cm;  $BD = 7$  cm, then the area of parallelogram ABCD is

- A.  $45 \text{ cm}^2$                       B.  $35 \text{ cm}^2$                       C.  $25 \text{ cm}^2$                       D.  $10 \text{ cm}^2$

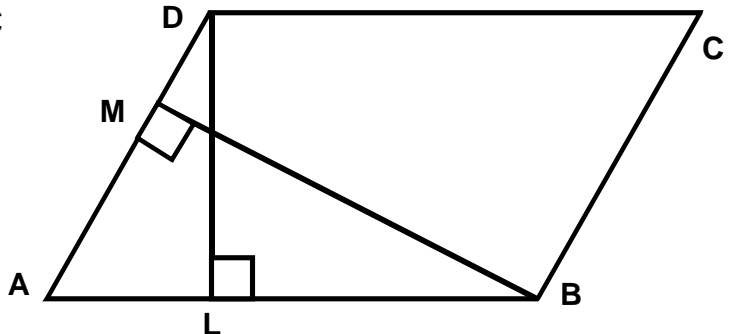
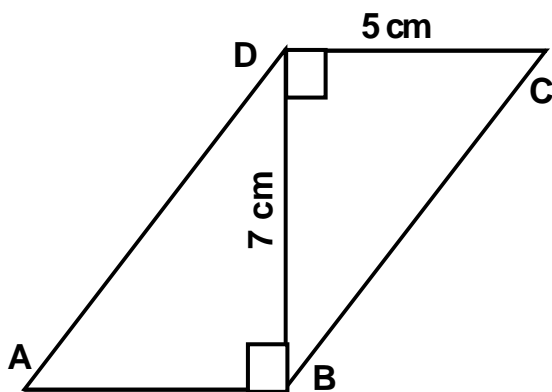

15. In the above figure, ABCD is a parallelogram;  $AB = 10$  cm;  $BM = 8$  cm and  $DL = 6$  cm, then  $AD =$

- A. 15 cm                      B. 13 cm                      C. 11 cm                      D. none of these

**PRACTICE QUESTIONS**  
**CLASS IX: CHAPTER – 9**  
**AREAS OF  $\parallel^{\text{gms}}$  AND TRIANGLES**

1. ABCD is a parallelogram x and y are midpoints of BC and CD respectively. Prove that  $\text{ar}(\triangle AXY) = \frac{3}{8}(\parallel^{\text{gm}}\text{ABCD})$
2. The medians BE and CF of a triangle ABC intersect at G. Prove that  $\text{ar}(\triangle GBC) =$  area of quadrilateral AFGE.
3. In fig. PQRS is a square and T and U are respectively, the midpoints of PS and QR. Find the area of  $\triangle OTS$  if  $PQ = 8\text{cm}$ .

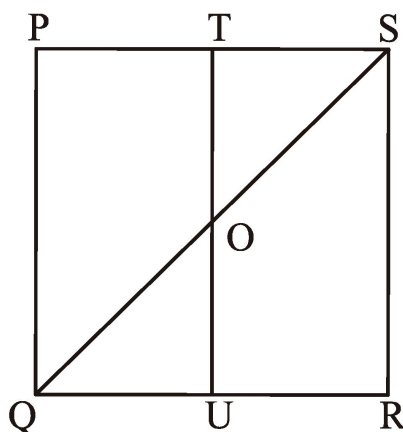

4. In fig. ABCD, ABFE and CDEF are parallelograms. Prove that  $\text{ar}(\triangle ADE) = \text{ar}(\triangle BCF)$ .

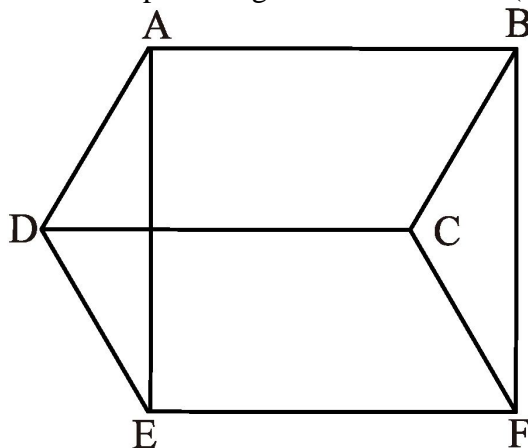

5. In fig. ABCD is a trapezium in which  $AB \parallel CD$ . Prove that area of  $\triangle AOD =$  area of  $\triangle BOC$ .

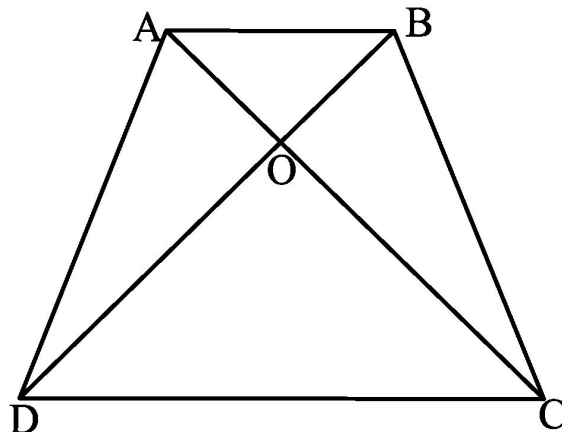

6. The diagonals of parallelogram ABCD intersect at a point O. Through O, a line is drawn to intersect AD at P and BC at Q. Show PQ divides the parallelogram into two parts of equal area.
7. In the fig. O is any point on the diagonal BD of the parallelogram ABCD. Prove that  $\text{ar}(\triangle OAB) = \text{ar}(\triangle OBC)$ .

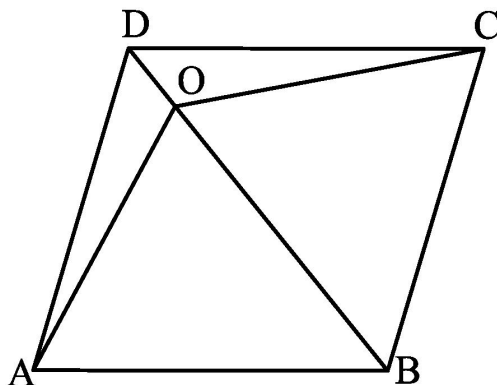

8. Show that the diagonals of a parallelogram divide it into four triangles of equal area.
9. In fig. ABCD is a parallelogram and BC is produced to a point Q such that  $AD = CQ$ . If AQ intersects DC at P, show that  $\text{ar}(\triangle BPC) = \text{ar}(\triangle DPQ)$

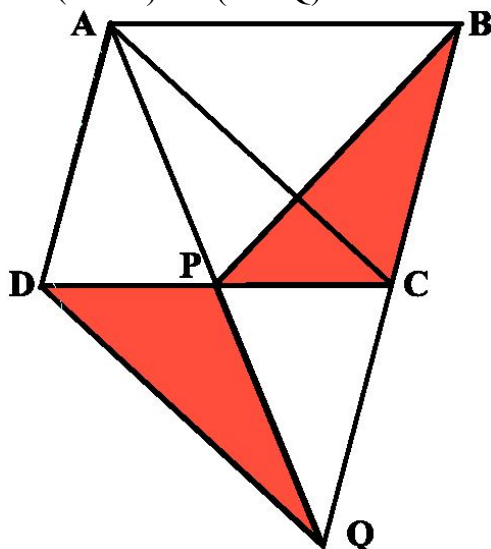

10. Prove that “Two parallelograms on the same base and between the same parallels are equal in area”.
11. Prove that “Two triangles on the same base and between the same parallels are equal in area”.
12. Prove that a median of a triangle divides it into two equal parts
13. If a triangle and a parallelogram are on the same base and between the same parallels, then prove that the area of the triangle is equal to half the area of the parallelogram.
14. If E,F,G and H are respectively the mid-points of the sides of a parallelogram ABCD, show that  $\text{ar}(\text{EFGH}) = \frac{1}{2} \text{ar}(\text{ABCD})$
15. Show that the diagonals of a parallelogram divide it into four triangles of equal area.
16. D and E are points on sides AB and AC respectively of  $\triangle ABC$  such that  $\text{ar}(\triangle DBC) = \text{ar}(\triangle EBC)$ . Prove that  $DE \parallel BC$ .

17. XY is a line parallel to side BC of a triangle ABC. If BE || AC and CF || AB meet XY at E and F respectively, show that ar (ABE) = ar (ACF)

18. In the below figure PSDA is a parallelogram. Points Q and R are taken on PS such that PQ = QR = RS and PA || QB || RC. Prove that ar (PQE) = ar (CFD).

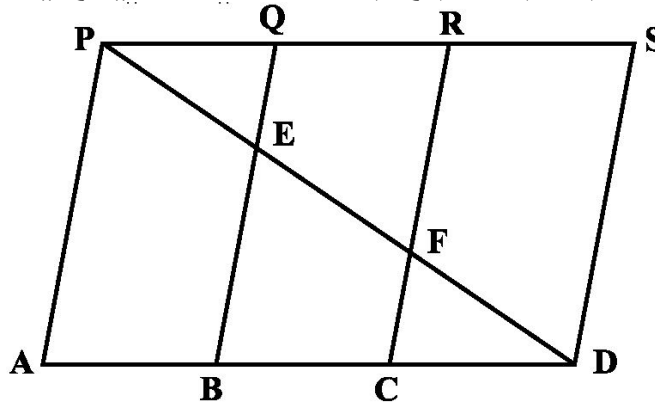

19. X and Y are points on the side LN of the triangle LMN such that LX = XY = YN. Through X, a line is drawn parallel to LM to meet MN at Z (See Fig. 9.12). Prove that ar (LZY) = ar (MZYX)

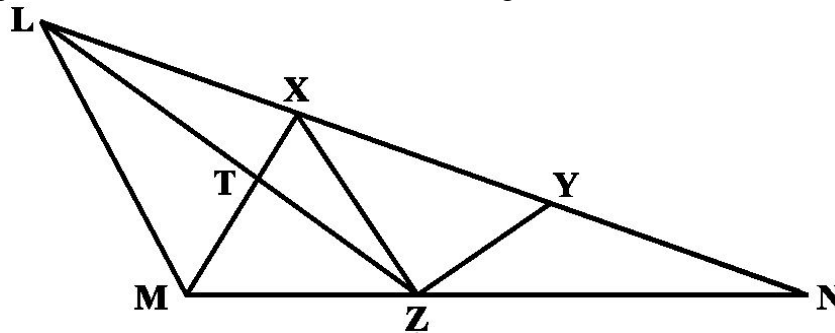

20. The area of the parallelogram ABCD is  $90 \text{ cm}^2$ . Find (i) ar (ABEF) (ii) ar (ABD) (iii) ar (BEF).

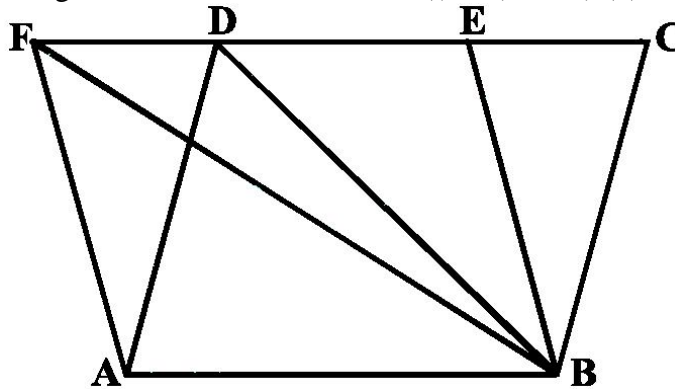

21. In  $\Delta ABC$ , D is the mid-point of AB and P is any point on BC. If  $CQ \parallel PD$  meets AB in Q, then prove that  $\text{ar} (BPQ) = \frac{1}{2} \text{ar} (ABC)$ .

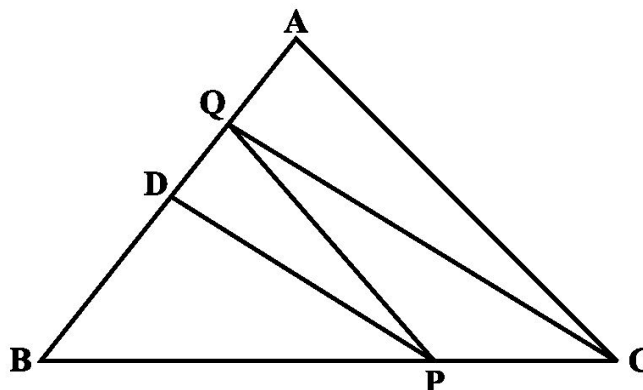

22. ABCD is a square. E and F are respectively the midpoints of BC and CD. If R is the mid-point of EF, prove that  $\text{ar}(\text{AER}) = \text{ar}(\text{AFR})$

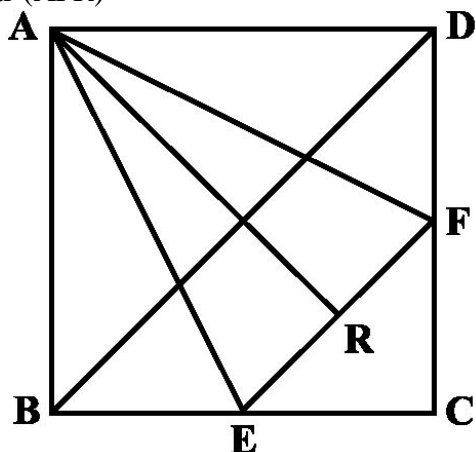

23. O is any point on the diagonal PR of a parallelogram PQRS. Prove that  $\text{ar}(\text{PSO}) = \text{ar}(\text{PQO})$ .

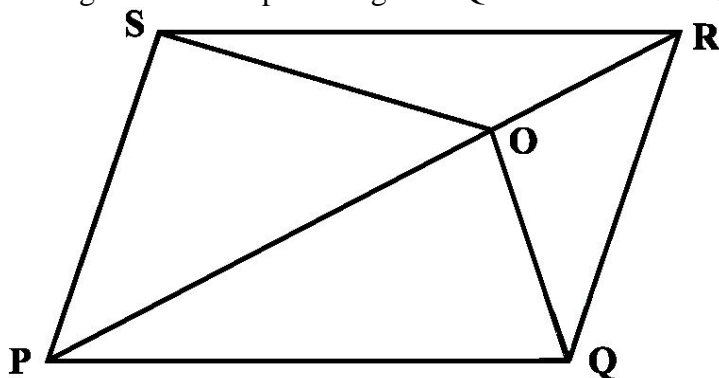

24. ABCD is a parallelogram in which BC is produced to E such that  $CE = BC$ . AE intersects CD at F. If  $\text{ar}(\text{DFB}) = 3 \text{ cm}^2$ , find the area of the parallelogram ABCD.

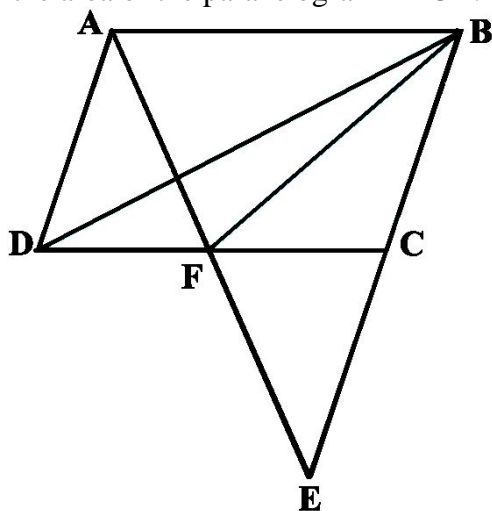

25. In trapezium ABCD,  $AB \parallel DC$  and L is the mid-point of BC. Through L, a line  $PQ \parallel AD$  has been drawn which meets AB in P and DC produced in Q. Prove that  $\text{ar}(\text{ABCD}) = \text{ar}(\text{APQD})$ .

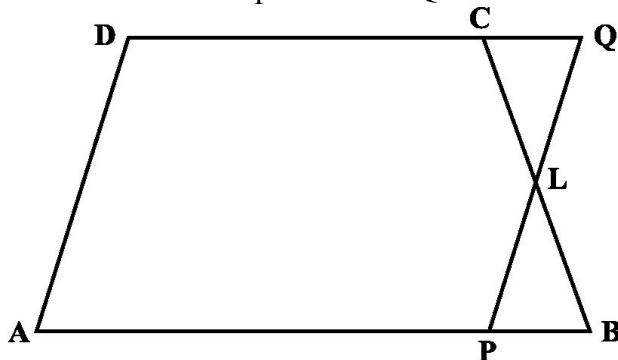

26. If the mid-points of the sides of a quadrilateral are joined in order, prove that the area of the parallelogram so formed will be half of the area of the given quadrilateral.

27. In the below figure,  $l, m, n$ , are straight lines such that  $l \parallel m$  and  $n$  intersects  $l$  at P and  $m$  at Q. ABCD is a quadrilateral such that its vertex A is on  $l$ . The vertices C and D are on  $m$  and  $AD \parallel n$ . Show that  $\text{ar}(ABCQ) = \text{ar}(ABCDP)$

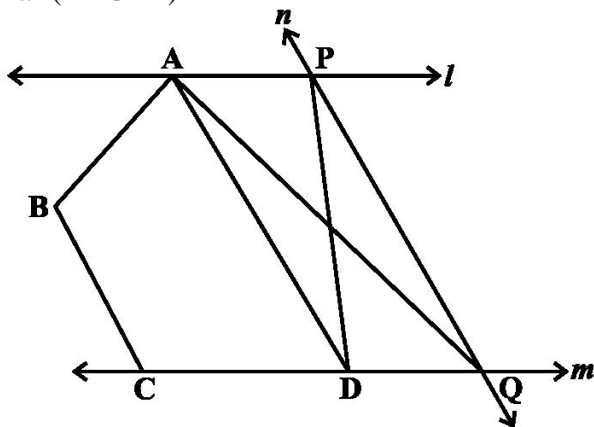

28. In the below figure,  $BD \parallel CA$  E is mid-point of CA and  $BD = \frac{1}{2} CA$ .

Prove that  $\text{ar}(ABC) = 2\text{ar}(DBC)$

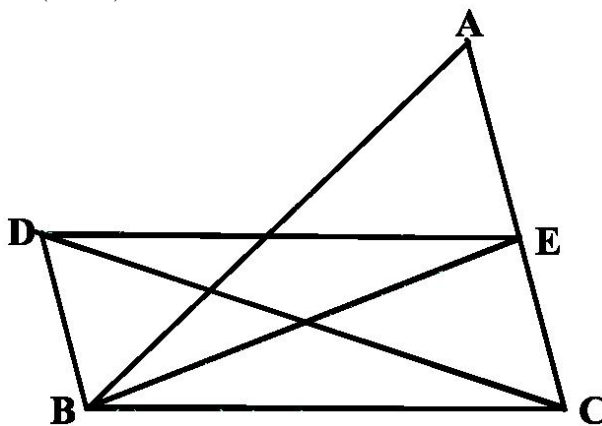

29. In the below figure, ABCD is a parallelogram. Points P and Q on BC trisect BC in three equal parts. Prove that  $\text{ar}(APQ) = \text{ar}(DPQ) = \frac{1}{6} \text{ar}(ABCD)$

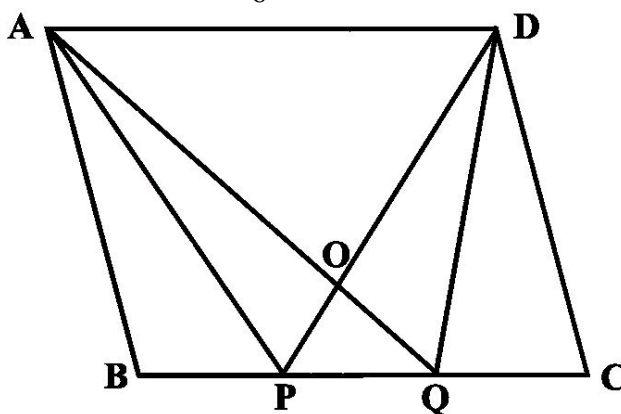

30. A point E is taken on the side BC of a parallelogram ABCD. AE and DC are produced to meet at F. Prove that  $\text{ar}(ADF) = \text{ar}(ABFC)$

31. The diagonals of a parallelogram ABCD intersect at a point O. Through O, a line is drawn to intersect AD at P and BC at Q. Show that PQ divides the parallelogram into two parts of equal area.

32. In the below figure, X and Y are the mid-points of AC and AB respectively, QP  $\parallel$  BC and CYQ and BXP are straight lines. Prove that ar (ABP) = ar (ACQ).

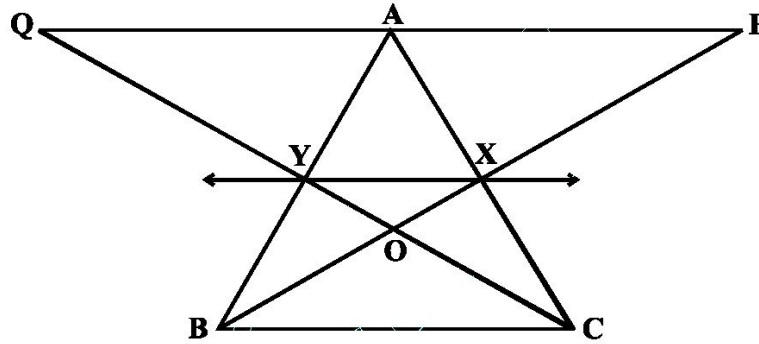

33. Parallelogram ABCD and rectangle ABEF are on the same base AB and have equal areas. Show that the perimeter of the parallelogram is greater than that of the rectangle.

34. In the below figure, ABCD and AEFD are two parallelograms. Prove that ar (PEA) = ar (QFD)

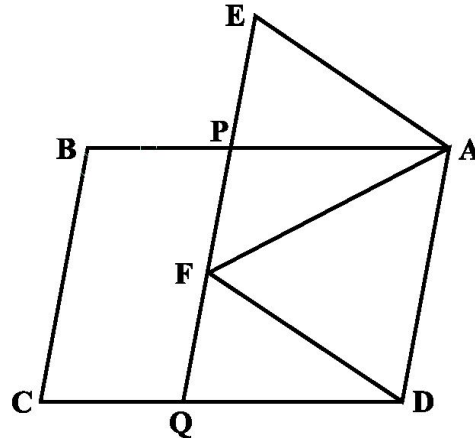

35. In the below figure, ABCDE is any pentagon. BP drawn parallel to AC meets DC produced at P and EQ drawn parallel to AD meets CD produced at Q. Prove that ar (ABCDE) = ar (APQ)

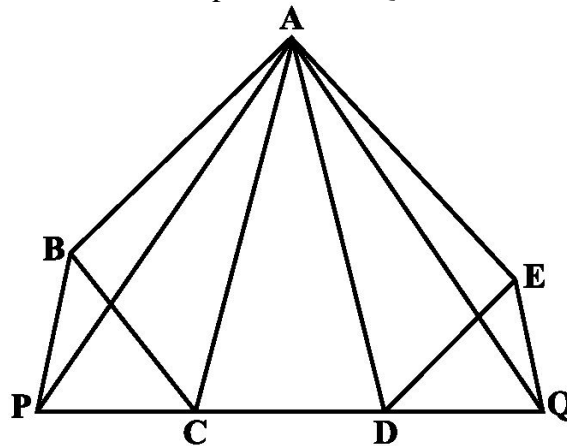

36. In the below figure, CD  $\parallel$  AE and CY  $\parallel$  BA. Prove that ar (CBX) = ar (AXY)

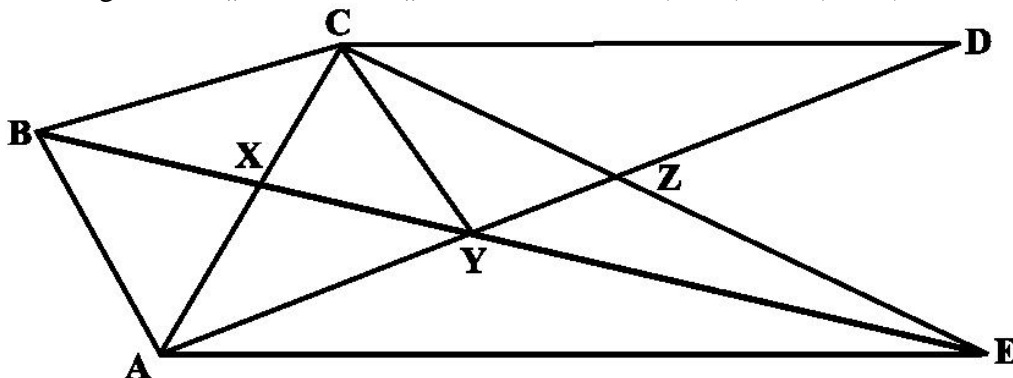

37. In fig. P is a point in the interior of a parallelogram ABCD. Show that

(i)  $\text{ar}(\text{APB}) + \text{ar}(\text{PCD}) = \frac{1}{2} \text{ar}(\text{ABCD})$

(ii)  $\text{ar}(\text{APD}) + \text{ar}(\text{PBC}) = \text{ar}(\text{APB}) + \text{ar}(\text{PCD})$

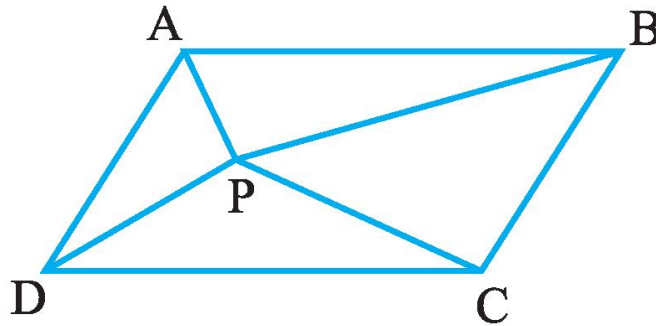

38. In Fig. ABCD is a quadrilateral and BE || AC and also BE meets DC produced at E. Show that area of  $\Delta ADE$  is equal to the area of the quadrilateral ABCD.

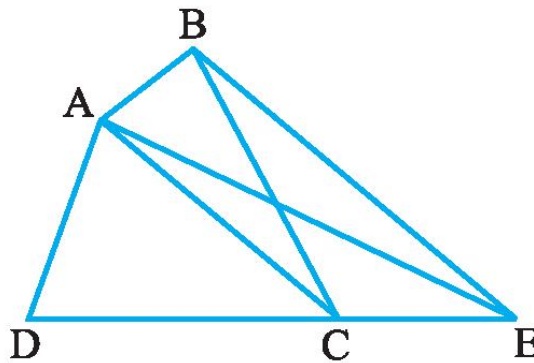

39. Diagonals AC and BD of a trapezium ABCD with  $AB \parallel DC$  intersect each other at O. Prove that  $\text{ar}(\text{AOD}) = \text{ar}(\text{BOC})$ .

40. Diagonals AC and BD of a quadrilateral ABCD intersect each other at O such that  $\text{ar}(\text{AOD}) = \text{ar}(\text{BOC})$ . Prove that ABCD is a trapezium.

41. ABCD is a trapezium with  $AB \parallel DC$ . A line parallel to AC intersects AB at X and BC at Y. Prove that  $\text{ar}(\text{ADX}) = \text{ar}(\text{ACY})$ .

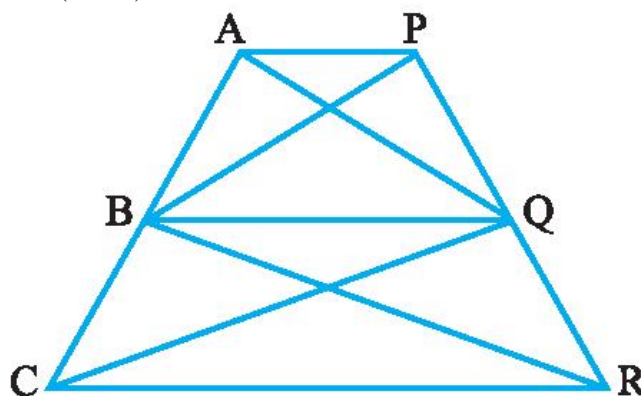

42. In the above Fig.  $AP \parallel BQ \parallel CR$ . Prove that  $\text{ar}(\text{AQC}) = \text{ar}(\text{PBR})$ .

43. Diagonals AC and BD of a quadrilateral ABCD intersect at O in such a way that  $\text{ar}(\text{AOD}) = \text{ar}(\text{BOC})$ . Prove that ABCD is a trapezium.

44. The medians BE and CF of a triangle ABC intersect at G. Prove that the area of  $\Delta GBC =$  area of the quadrilateral AFGE.



45. Diagonals AC and BD of a quadrilateral ABCD intersect each other at P. Show that  $\text{ar}(\text{APB}) \times \text{ar}(\text{CPD}) = \text{ar}(\text{APD}) \times \text{ar}(\text{BPC})$ .
46. ABCD is a trapezium in which  $AB \parallel DC$ ,  $DC = 30$  cm and  $AB = 50$  cm. If X and Y are, respectively the mid-points of AD and BC, prove that  $\text{ar}(\text{DCYX}) = \frac{7}{9} \text{ar}(\text{XYBA})$
47. In  $\Delta ABC$ , if L and M are the points on AB and AC, respectively such that  $LM \parallel BC$ . Prove that  $\text{ar}(\text{LOB}) = \text{ar}(\text{MOC})$
48. If the medians of a  $\Delta ABC$  intersect at G, show that  $\text{ar}(\text{AGB}) = \text{ar}(\text{AGC}) = \text{ar}(\text{BGC}) = \frac{1}{3} \text{ar}(\text{ABC})$
49. Prove that the area of rhombus is equal to half the rectangle contained by its diagonals.
50. A point O inside a rectangle ABCD is joined to the vertices. Prove that the sum of the areas of a pair of opposite triangles so formed is equal to the sum of the other pair of triangles.
51. The medians BE and CF of a triangle ABC intersect at G. Prove that area of  $\Delta GBC =$  area of quadrilateral AFGE.
52. A villager Itwaari has a plot of land of the shape of a quadrilateral. The Gram Panchayat of the village decided to take over some portion of his plot from one of the corners to construct a Health Centre. Itwaari agrees to the above proposal with the condition that he should be given equal amount of land in lieu of his land adjoining his plot so as to form a triangular plot. Explain how this proposal will be implemented.
53. P and Q are respectively the mid-points of sides AB and BC of a triangle ABC and R is the mid-point of AP, show that  
 (i)  $\text{ar}(\text{PRQ}) = \frac{1}{2} \text{ar}(\text{ARC})$  (ii)  $\text{ar}(\text{RQC}) = \frac{3}{8} \text{ar}(\text{ABC})$  (iii)  $\text{ar}(\text{PBQ}) = \text{ar}(\text{ARC})$
54. A quadrilateral ABCD is such that the diagonal BD divides its area in two equal parts. Prove that BD bisects AC.
55. D, E and F are respectively the mid-points of the sides BC, CA and AB of a  $\Delta ABC$ . Show that  
 (i) BDEF is a parallelogram. (ii)  $\text{ar}(\text{DEF}) = \frac{1}{4} \text{ar}(\text{ABC})$  (iii)  $\text{ar}(\text{BDEF}) = \frac{1}{2} \text{ar}(\text{ABC})$ .
- .....

**MCQ WORKSHEET-I**  
**CLASS IX: CHAPTER – 10**  
**CIRCLES**

1. The centre of a circle lies in \_\_\_\_\_ of the circle.  
(a) exterior (b) interior (c) boundary (d) none of these
2. A point, whose distance from the centre of a circle is greater than its radius lies in of the circle.  
(a) exterior (b) interior (c) boundary (d) none of these
3. The longest chord of a circle is a \_\_\_\_\_ of the circle.  
(a) diameter (b) semicircle (c) chord (d) sector
4. Segment of a circle is the region between an arc and \_\_\_\_\_ of the circle.  
(a) diameter (b) semicircle (c) chord (d) sector
5. A circle divides the plane, on which it lies, in parts.  
(a) two (b) three (c) four (d) five
6. *Equal chords of a circle subtend \_\_\_\_\_ angles at the centre.*  
(a) half (b) one third (c) one fourth (d) equal
7. *If the angles subtended by the chords of a circle at the centre are equal, then the chords are \_\_\_\_\_.*  
(a) half (b) one third (c) one fourth (d) equal
8. *The perpendicular from the centre of a circle to a chord \_\_\_\_\_ the chord.*  
(a) trisect (b) bisect (c) coincide (d) none of these.
9. *The line drawn through the centre of a circle to \_\_\_\_\_ a chord is perpendicular to the chord.*  
(a) trisect (b) bisect (c) coincide (d) none of these.
10. *There is one and only one circle passing through \_\_\_\_\_ given non-collinear points.*  
(a) two (b) three (c) four (d) five
11. *Chords equidistant from the centre of a circle are \_\_\_\_\_ in length.*  
(a) half (b) one third (c) one fourth (d) equal
12. *The angle subtended by an arc at the centre is \_\_\_\_\_ the angle subtended by it at any point on the remaining part of the circle.*  
(a) half (b) double (c) triple (d) equal
13. *Angles in the same segment of a circle are equal.*  
(a) half (b) double (c) triple (d) equal
14. *The sum of either pair of opposite angles of a cyclic quadrilateral is \_\_\_\_\_.*  
(a)  $180^\circ$ . (b)  $360^\circ$  (c)  $90^\circ$  (d) none of these
15. *If the sum of a pair of opposite angles of a quadrilateral is \_\_\_\_\_, the quadrilateral is cyclic.*  
(a)  $180^\circ$ . (b)  $360^\circ$  (c)  $90^\circ$  (d) none of these

**MCQ WORKSHEET-II**  
**CLASS IX: CHAPTER – 10**  
**CIRCLES**

1. The length of a chord of circle of radius 10 cm is 12 cm. Determine the distance of the chord from the centre  
(a) 8 cm      (b) 7 cm      (c) 6 cm      (d) 5 cm
2. The length of a chord of circle is 4 cm. If its perpendicular distance from the centre is 1.5 cm, determine the radius of the circle.  
(a) 2.5 cm      (b) 1.5 cm      (c) 6 cm      (d) 5 cm
3. The radius of the circle is 5 cm and distance of the chord from the centre of the circle is 4 cm. Find the length of the chord.  
(a) 8 cm      (b) 7 cm      (c) 6 cm      (d) 5 cm
4. Find the length of a chord, which is at a distance of 24 cm from the centre of a circle whose diameter is 50 cm.  
(a) 12 cm      (b) 14 cm      (c) 16 cm      (d) 15 cm
5. Two points A and B are 16 cm apart. A circle with radius 17 cm is drawn to pass through these points. Find the distance of AB from the centre of the circle.  
(a) 12 cm      (b) 14 cm      (c) 16 cm      (d) 15 cm
6. If the length of a chord of a circle at a distance of 5 cm from the centre of the circle is 24 cm, find the radius of the circle.  
(a) 13 cm      (b) 14 cm      (c) 16 cm      (d) 15 cm
7. A chord 6 cm long is drawn in a circle with a diameter equal to 10 cm. Find its perpendicular distance from the centre.  
(a) 4 cm      (b) 7 cm      (c) 6 cm      (d) 5 cm
8. If the length of a chord of a circle at a distance of 24 cm from the centre of the circle is 36 cm, find the length of the greatest chord of the circle.  
(a) 80 cm      (b) 70 cm      (c) 60 cm      (d) 50 cm
9. AB is a chord of the circle with centre O and radius 13 cm. If  $OM \perp AB$  and  $OM = 5$  cm, find the length of the chord AB.  
(a) 24 cm      (b) 27 cm      (c) 26 cm      (d) 25 cm
10. A chord of a circle of radius 7.5 cm with centre O is of length 9 cm. Find the its distance from the centre.  
(a) 4 cm      (b) 7 cm      (c) 6 cm      (d) 5 cm
11. Two circles of radii 5 cm and 3 cm intersect at two points and the distance between their centres is 4 cm. Find the length of the common chord.  
(a) 4 cm      (b) 7 cm      (c) 6 cm      (d) 5 cm
12. In a circle of radius 25 cm, AB and AC are two chords, such that  $AB = AC = 30$  cm . Find the length of the chord.  
(a) 40 cm      (b) 48 cm      (c) 60 cm      (d) 50 cm

**MCQ WORKSHEET-III**  
**CLASS IX: CHAPTER – 10**  
**CIRCLES**

1. In below Fig, ABCD is a cyclic quadrilateral in which AC and BD are its diagonals. If  $\angle DBC = 55^\circ$  and  $\angle BAC = 45^\circ$ , find  $\angle BCD$ .

(a)  $80^\circ$       (b)  $60^\circ$       (c)  $90^\circ$       (d) none of these

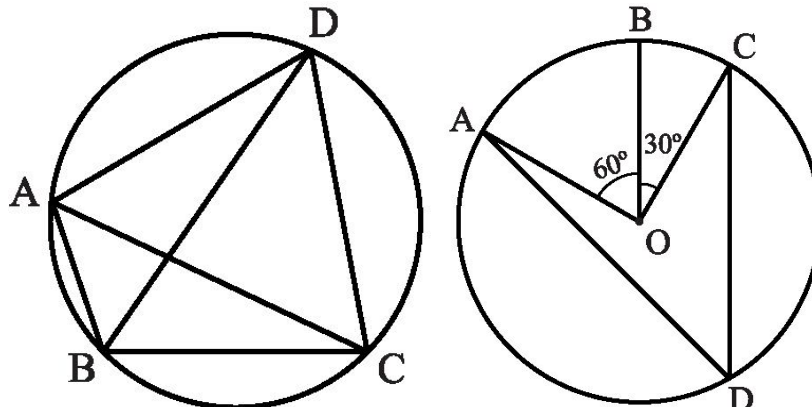

2. In above sided Fig, A, B and C are three points on a circle with centre O such that  $\angle BOC = 30^\circ$  and  $\angle AOB = 60^\circ$ . If D is a point on the circle other than the arc ABC, find  $\angle ADC$ .

(a)  $45^\circ$       (b)  $60^\circ$       (c)  $90^\circ$       (d) none of these

3. A chord of a circle is equal to the radius of the circle. Find the angle subtended by the chord at a point on the minor arc

(a)  $150^\circ$       (b)  $30^\circ$       (c)  $60^\circ$       (d) none of these

4. A chord of a circle is equal to the radius of the circle. Find the angle subtended by the chord at a point on the major arc.

(a)  $150^\circ$       (b)  $30^\circ$       (c)  $60^\circ$       (d) none of these

5. In the below Fig.,  $\angle ABC = 69^\circ$ ,  $\angle ACB = 31^\circ$ , find  $\angle BDC$ .

(a)  $80^\circ$       (b)  $60^\circ$       (c)  $90^\circ$       (d)  $100^\circ$

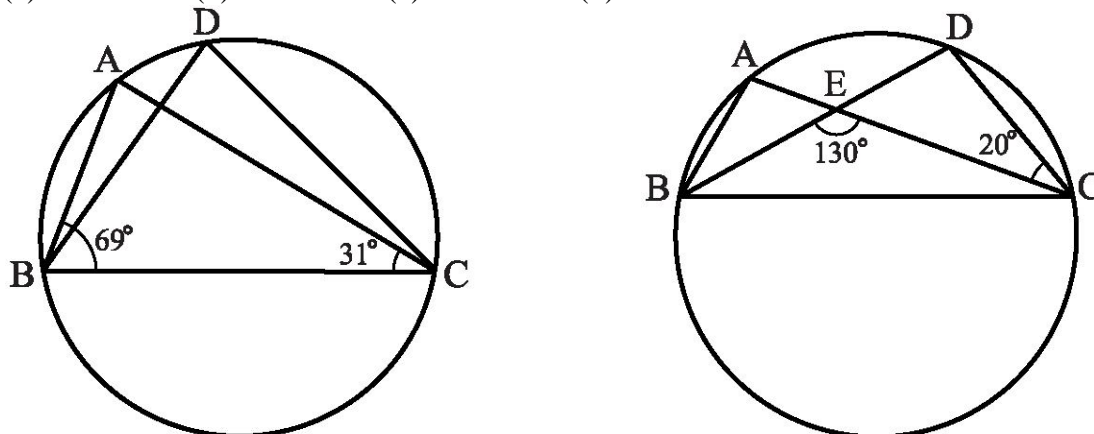

6. In the above sided Fig., A, B, C and D are four points on a circle. AC and BD intersect at a point E such that  $\angle BEC = 130^\circ$  and  $\angle ECD = 20^\circ$ . Find  $\angle BAC$ .

(a)  $110^\circ$       (b)  $150^\circ$       (c)  $90^\circ$       (d)  $100^\circ$

7. ABCD is a cyclic quadrilateral whose diagonals intersect at a point E. If  $\angle DBC = 70^\circ$ ,  $\angle BAC$  is  $30^\circ$ , find  $\angle BCD$ .

(a)  $80^\circ$       (b)  $60^\circ$       (c)  $90^\circ$       (d)  $100^\circ$

8. ABCD is a cyclic quadrilateral. If  $\angle BCD = 100^\circ$ ,  $\angle ABD$  is  $30^\circ$ , find  $\angle ACD$ .  
 (a)  $80^\circ$       (b)  $60^\circ$       (c)  $90^\circ$       (d)  $70^\circ$
9. ABCD is a cyclic quadrilateral. If  $\angle DBC = 80^\circ$ ,  $\angle BAC$  is  $40^\circ$ , find  $\angle BCD$ .  
 (a)  $80^\circ$       (b)  $60^\circ$       (c)  $90^\circ$       (d)  $70^\circ$
10. ABCD is a cyclic quadrilateral in which BC is parallel to AD,  $\angle ADC = 110^\circ$  and  $\angle BAC = 50^\circ$ .  
 Find  $\angle DAC$   
 (a)  $80^\circ$       (b)  $60^\circ$       (c)  $90^\circ$       (d)  $170^\circ$

11. In the below figure,  $\angle POQ = 80^\circ$ , find  $\angle PAQ$   
 (a)  $80^\circ$       (b)  $40^\circ$       (c)  $100^\circ$       (d) none of these

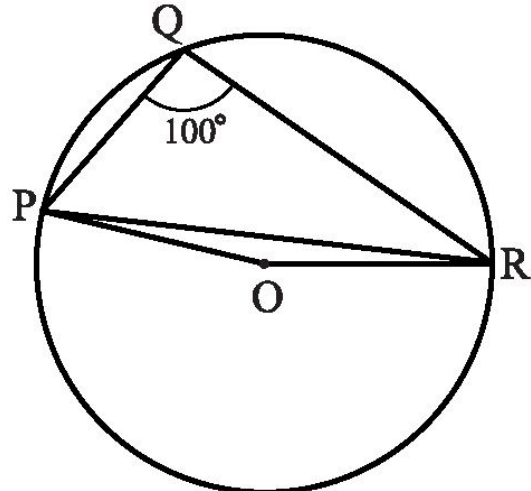
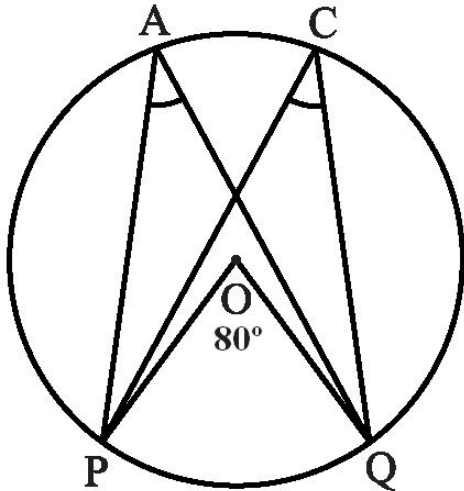

12. In the above figure,  $\angle PQR = 100^\circ$ , where P, Q and R are points on a circle with centre O. Find  $\angle OPR$ .  
 (a)  $80^\circ$       (b)  $40^\circ$       (c)  $10^\circ$       (d) none of these

**MCQ WORKSHEET-IV**  
**CLASS IX: CHAPTER – 10**  
**CIRCLES**

1. Distance of chord AB from the centre is 12 cm and length of the chord is 10 cm. Then diameter of the circle is  
A. 26 cm                      B. 13 cm                      C.  $\sqrt{244}$  cm                      D. 20 cm
2. Two circles are drawn with side AB and AC of a triangle ABC as diameters. Circles intersect at a point D, Then  
A.  $\angle ADB$  and  $\angle ADC$  are equal                      B.  $\angle ADB$  and  $\angle ADC$  are complementary  
C. Points B, D, C are collinear                      D. none of these
3. The region between a chord and either of the arcs is called  
A. an arc                      B. a sector                      C. a segment                      D. a semicircle
4. A circle divides the plane in which it lies, including circle in  
A. 2 parts                      B. 3 parts                      C. 4 parts                      D. 5 parts
5. If diagonals of a cyclic quadrilateral are the diameters of a circle through the vertices of a quadrilateral, then quadrilateral is a  
A. parallelogram                      B. square                      C. rectangle                      D. trapezium
6. Given three non collinear points, then the number of circles which can be drawn through these three points are  
A. one                      B. zero                      C. two                      D. infinite

Distance of chord AB from the centre is 12 cm and length of the chord is 10cm. Then diameter of the circle is

7. In a circle with centre O, AB and CD are two diameters perpendicular to each other. The length of chord AC is  
A. 2 AB                      B.  $\sqrt{2}$  AB                      C.  $\frac{1}{2}$  AB                      D.  $\frac{1}{\sqrt{2}}$  AB
8. If AB is a chord of a circle, P and Q are the two points on the circle different from A and B, then  
A.  $\angle APB = \angle AQB$   
B.  $\angle APB + \angle AQB = 180^\circ$   
C.  $\angle APB + \angle AQB = 90^\circ$   
D.  $\angle APB + \angle AQB = 180^\circ$

9. In the above figure,  $\angle PQR = 90^\circ$ , where P, Q and R are points on a circle with centre O. Find reflex  $\angle POR$ .  
 (a)  $180^\circ$       (b)  $140^\circ$       (c)  $45^\circ$       (d) none of these

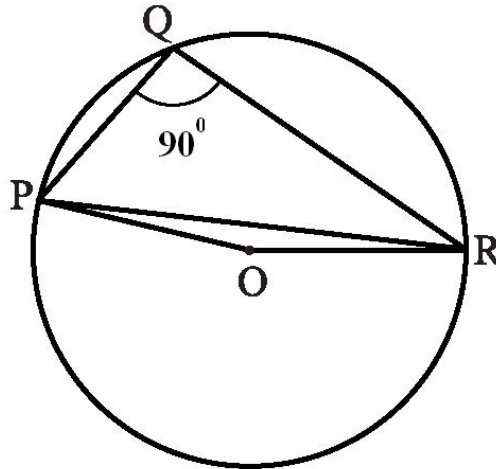

10. In below Fig, ABCD is a cyclic quadrilateral in which AC and BD are its diagonals. If  $\angle DBC = 60^\circ$  and  $\angle BAC = 30^\circ$ , find  $\angle BCD$ .  
 (a)  $80^\circ$       (b)  $60^\circ$       (c)  $90^\circ$       (d) none of these

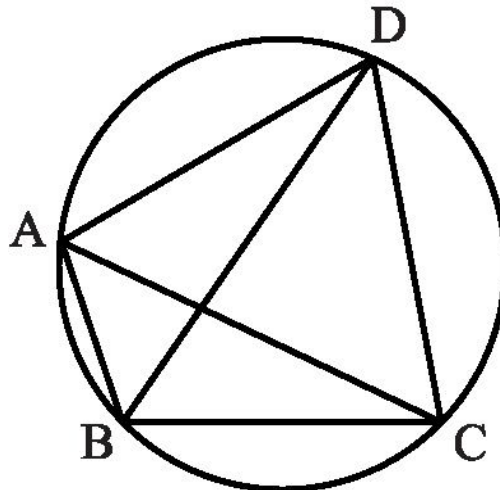

**PRACTICE QUESTIONS**  
**CHAPTER – 10: CIRCLES**

1. Prove that “*Equal chords of a circle subtend equal angles at the centre*”.
2. Prove that “*Chords of a circle which subtends equal angles at the centre are equal*”.
3. Prove that “*The perpendicular from the centre of a circle to a chord bisects the chord.*”
4. Prove that “*The line drawn through the centre of a circle to bisect a chord is perpendicular to the chord*”.
5. Prove that “*Chords equidistant from the centre of a circle are equal in length*”
6. Prove that “*Chords of a circle which are equidistant from the centre are equal*”
7. Prove that “*Of any two chords of a circle then the one which is larger is nearer to the centre.*”
8. Prove that “*Of any two chords of a circle then the one which is nearer to the centre is larger.*”
9. Prove that “*line joining the midpoints of two equal chords of circle subtends equal angles with the chord.*”
10. Prove that “*if two chords of a circle bisect each other they must be diameters.*”
11. If two chords of a circle are equally inclined to the diameter through their point of intersection, prove that the chords are equal.
12. Prove that “*The angle subtended by an arc at the centre is double the angle subtended by it at any point on the remaining part of the circle.*”
13. Prove that “*Angles in the same segment of a circle are equal.*”
14. Prove that “*Angle in a semicircle is a right angle.*”
15. Prove that “*Arc of a circle subtending a right angle at any point of the circle in its alternate segment is a semicircle.*”
16. Prove that “*Any angle subtended by a minor arc in the alternate segment is acute and any angle subtended by a major arc in the alternate segment is obtuse.*”
17. Prove that “*If a line segment joining two points subtends equal angles at two other points lying on the same side of the line segment, the four points are concyclic.*”
18. Prove that “*Circle drawn on any one side of the equal sides of an isosceles triangle as diameter bisects the side.*”
19. Prove that “*The sum of either pair of opposite angles of a cyclic quadrilateral is  $180^\circ$ .*”
20. Prove that “*If the sum of a pair of opposite angles of a quadrilateral is  $180^\circ$ , the quadrilateral is cyclic.*”



21. Prove that “If one side of the cyclic quadrilateral is produced then the exterior angle is equal to the interior opposite angle.”
22. Prove that “If two sides of a cyclic quadrilateral are parallel, then the remaining two sides are equal and the diagonals are also equal.”
23. Prove that “If two opposite sides of cyclic quadrilateral are equal, then the other two sides are parallel.”
24. Prove that “If two non parallel sides of a trapezium are equal, it is cyclic.”
25. Prove that “The sum of the angles in the four segments exterior to a cyclic quadrilateral is equal to 6 right angles.”
26. Two circles with centres A and B intersect at C and D. Prove that  $\angle ACB = \angle ADB$ .
27. Bisector AD of AC of  $\Delta ABC$  passes through the centre of the circumcircle of  $\Delta ABC$ . Prove that  $AB = AC$ .

28. In the below figure A, B and C are three points on a circle such that angles subtended by the chords AB and AC at the centre O are  $80^\circ$  and  $120^\circ$  respectively. Determine  $\angle BAC$ .

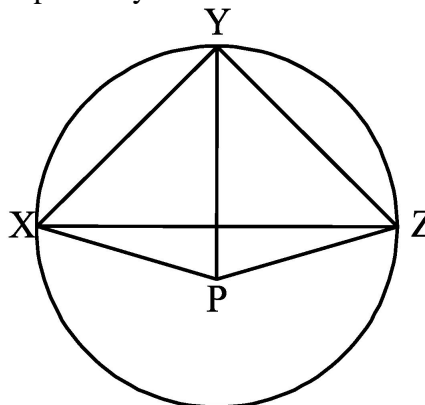
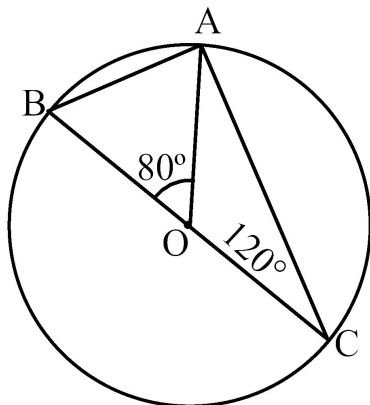

29. In the above right-sided figure, P is the centre of the circle. Prove that  $\angle XPZ = 2 (\angle XZY + \angle YXZ)$ .
30. Prove that the midpoint of the hypotenuse of a right triangle is equidistant from its vertices.
31. In the below figure ABCD is a cyclic quadrilateral, O is the centre of the circle. If  $\angle BOD = 160^\circ$ , find  $\angle BPD$ .

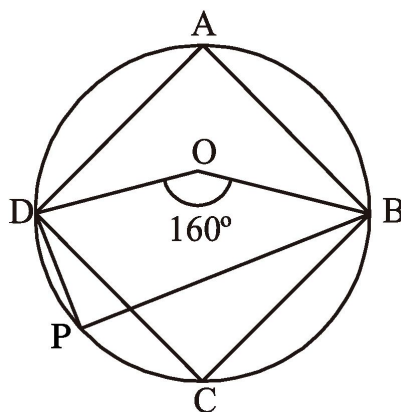

32. Prove that in a triangle if the bisector of any angle and the perpendicular bisector of its opposite side intersect, they will intersect on the circumcircle of the triangle.

33. The diagonals of a cyclic quadrilateral are at right angles. Prove that perpendiculars from the point of their intersection on any side when produced backward bisect the opposite side.
34. If two circles intersect at two points, prove that their centres lie on the perpendicular bisector of the common chord.
35. If two intersecting chords of a circle make equal angles with the diameter passing through their point of intersection, prove that the chords are equal.
36. Two circles of radii 5 cm and 3 cm intersect at two points and the distance between their centres is 4 cm. Find the length of the common chord.
37. If two equal chords of a circle intersect within the circle, prove that the segments of one chord are equal to corresponding segments of the other chord.
38. If two equal chords of a circle intersect within the circle, prove that the line joining the point of intersection to the centre makes equal angles with the chords.
39. In the below figure, AB is a diameter of the circle, CD is a chord equal to the radius of the circle. AC and BD when extended intersect at a point E. Prove that  $\angle AEB = 60^\circ$ .

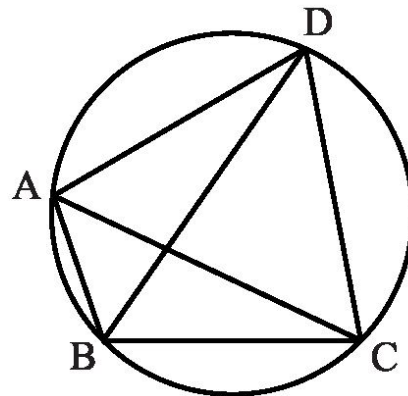
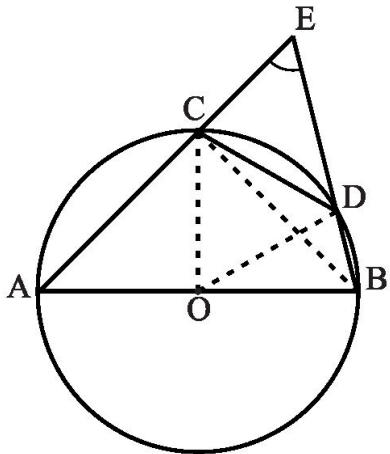

40. In the above right-sided figure, ABCD is a cyclic quadrilateral in which AC and BD are its diagonals. If  $\angle DBC = 55^\circ$  and  $\angle BAC = 45^\circ$ , find  $\angle BCD$ .
41. Prove that the quadrilateral formed (if possible) by the internal angle bisectors of any quadrilateral is cyclic.
42. ABCD is a cyclic quadrilateral whose diagonals intersect at a point E. If  $\angle DBC = 70^\circ$ ,  $\angle BAC$  is  $30^\circ$ , find  $\angle BCD$ . Further, if  $AB = BC$ , find  $\angle ECD$ .
43. If diagonals of a cyclic quadrilateral are diameters of the circle through the vertices of the quadrilateral, prove that it is a rectangle.
44. Two circles intersect at two points A and B. AD and AC are diameters to the two circles. Prove that B lies on the line segment DC.
45. Prove that the quadrilateral formed (if possible) by the internal angle bisectors of any quadrilateral is cyclic.
46. If the non-parallel sides of a trapezium are equal, prove that it is cyclic.

47. Two circles intersect at two points B and C. Through B, two line segments ABD and PBQ are drawn to intersect the circles at A, D and P, Q respectively. Prove that  $\angle ACP = \angle QCD$ .

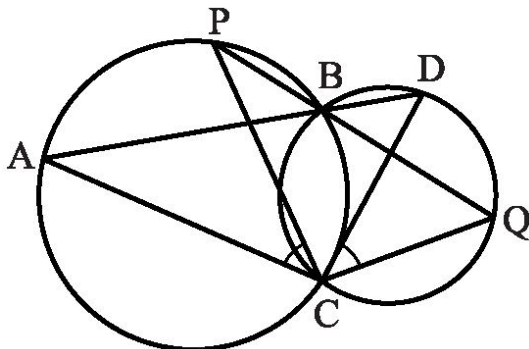

48. If circles are drawn taking two sides of a triangle as diameters, prove that the point of intersection of these circles lie on the third side.
49. Prove that the circle drawn with any side of a rhombus as diameter, passes through the point of intersection of its diagonals.
50. In the adjoining figure, A, B, C and D are four points on a circle. AC and BD intersect at a point E such that  $\angle BEC = 130^\circ$  and  $\angle ECD = 20^\circ$ . Find  $\angle BAC$ .

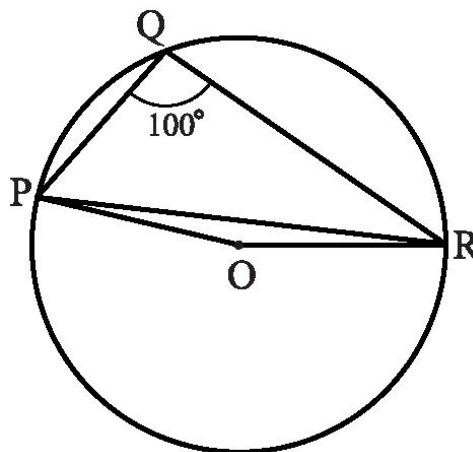
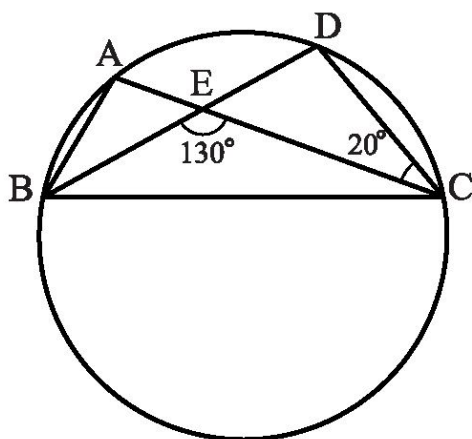

51. In the above right-sided figure,  $\angle PQR = 100^\circ$ , where P, Q and R are points on a circle with centre O. Find  $\angle OPR$ .
52. ABCD is a parallelogram. The circle through A, B and C intersect CD (produced if necessary) at E. Prove that  $AE = AD$ .
53. AC and BD are chords of a circle which bisect each other. Prove that (i) AC and BD are diameters, (ii) ABCD is a rectangle.
54. A chord of a circle is equal to the radius of the circle. Find the angle subtended by the chord at a point on the minor arc and also at a point on the major arc.
55. Prove that the circle drawn with any side of a rhombus as a diameter, passes through the point of its diagonals.
56. Bisectors of angles A, B and C of a triangles ABC intersect its circumcircle at D, E and F respectively. Prove that the angles of DDEF are  $90^\circ - \frac{A}{2}$ ,  $90^\circ - \frac{B}{2}$  and  $90^\circ - \frac{C}{2}$
57. Prove that the line of centres of two intersecting circles subtends equal angles at the two points of intersection.

58. In the adjoining Fig.,  $\angle ABC = 69^\circ$ ,  $\angle ACB = 31^\circ$ , find  $\angle BDC$ .

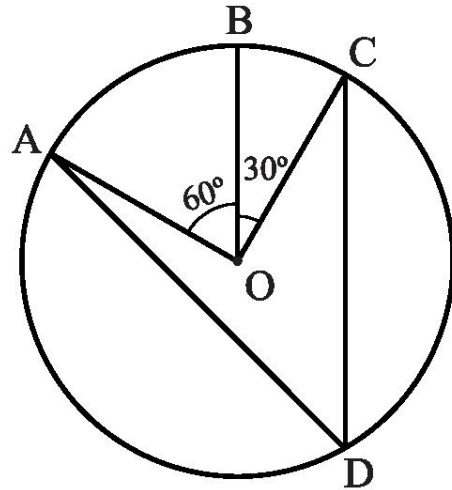
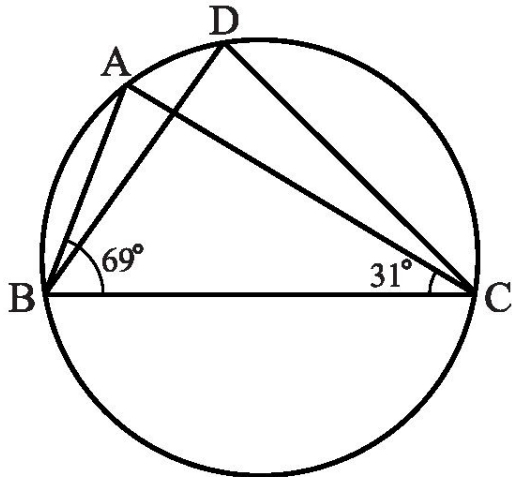

59. In the above right-sided figure, A, B and C are three points on a circle with centre O such that  $\angle BOC = 30^\circ$  and  $\angle AOB = 60^\circ$ . If D is a point on the circle other than the arc ABC, find  $\angle ADC$ .

60. In the below figure, AB and CD are two equal chords of a circle with centre O. OP and OQ are perpendiculars on chords AB and CD, respectively. If  $\angle POQ = 150^\circ$ , then find  $\angle APQ$ .

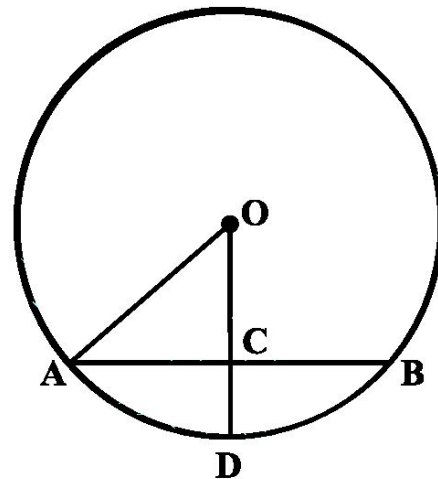
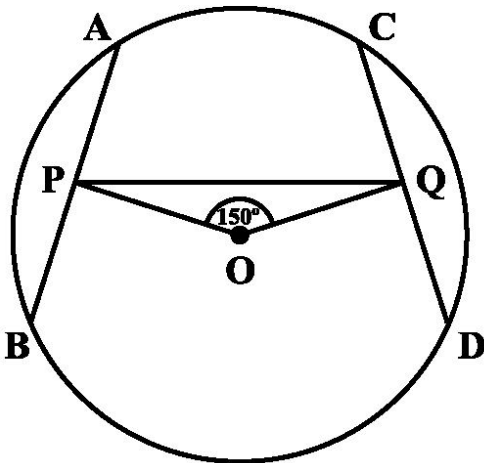

61. In the above right sided figure, if  $OA = 5$  cm,  $AB = 8$  cm and OD is perpendicular to AB, then find CD.

62. Two chords AB and CD of lengths 5 cm and 11 cm respectively of a circle are parallel to each other and are on opposite sides of its centre. If the distance between AB and CD is 6 cm, find the radius of the circle.

63. Two congruent circles intersect each other at points A and B. Through A any line segment PAQ is drawn so that P, Q lie on the two circles. Prove that  $BP = BQ$ .

64. In any triangle ABC, if the angle bisector of  $\angle A$  and perpendicular bisector of BC intersect, prove that they intersect on the circumcircle of the triangle ABC.

65. If arcs AXB and CYD of a circle are congruent, find the ratio of AB and CD.

66. If the perpendicular bisector of a chord AB of a circle PXAQBY intersects the circle at P and Q, prove that arc PXA  $\cong$  Arc PYB.

67. A, B and C are three points on a circle. Prove that the perpendicular bisectors of AB, BC and CA are concurrent.

68. AB and AC are two equal chords of a circle. Prove that the bisector of the angle BAC passes through the centre of the circle.

69. In the below figure, if  $\angle OAB = 40^\circ$ , then find  $\angle ACB$

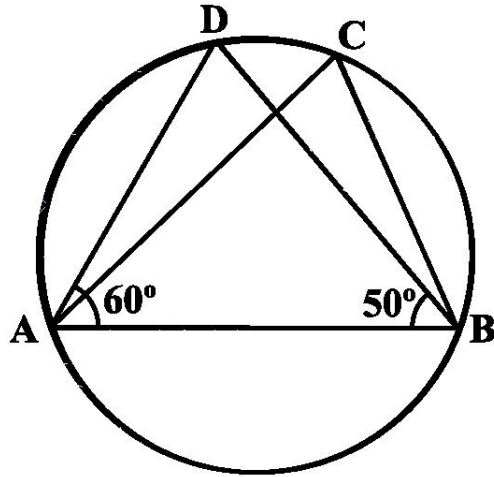
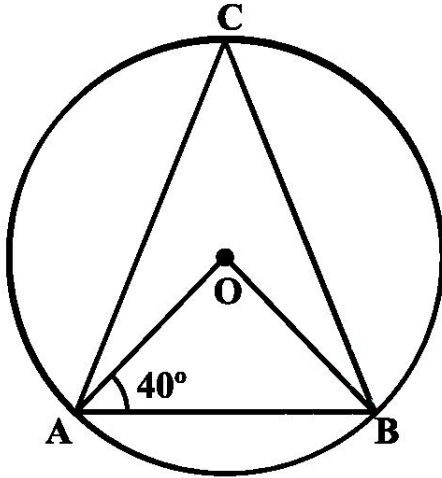

70. In the above right sided figure, if  $\angle DAB = 60^\circ$ ,  $\angle ABD = 50^\circ$  then find  $\angle ACB$ .

71. In the below figure, BC is a diameter of the circle and  $\angle BAO = 60^\circ$  then find  $\angle ADC$

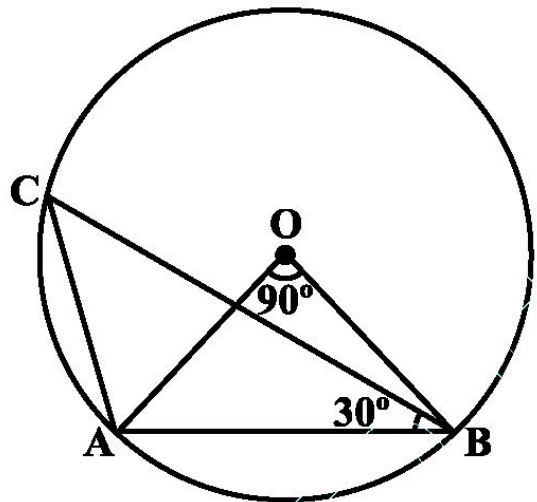
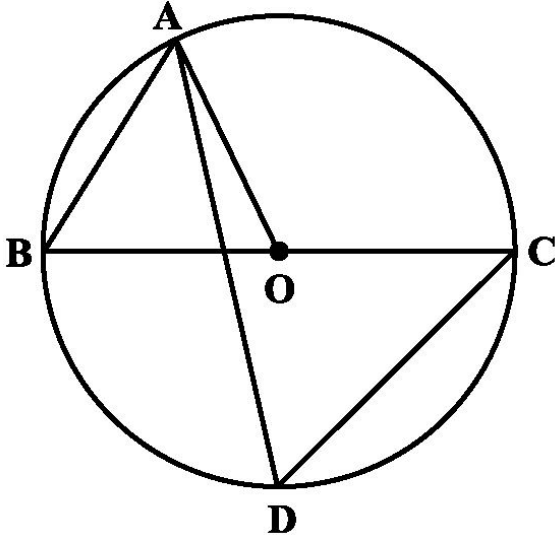

72. In above right sided figure,  $\angle AOB = 90^\circ$  and  $\angle ABC = 30^\circ$ , then find  $\angle CAO$

73. The lengths of two parallel chords of a circle are 6 cm and 8 cm. If the smaller chord is at distance 4 cm from the centre, what is the distance of the other chord from the centre?

74. A, B, C, D are four consecutive points on a circle such that  $AB = CD$ . Prove that  $AC = BD$ .

75. If a line segment joining mid-points of two chords of a circle passes through the centre of the circle, prove that the two chords are parallel.

76. ABCD is such a quadrilateral that A is the centre of the circle passing through B, C and D. Prove that  $\angle CBD + \angle CDB = \frac{1}{2} \angle BAD$

77. O is the circumcentre of the triangle ABC and D is the mid-point of the base BC. Prove that  $\angle BOD = \angle A$ .

78. On a common hypotenuse AB, two right triangles ACB and ADB are situated on opposite sides. Prove that  $\angle BAC = \angle BDC$ .

79. In the below figure, AOC is a diameter of the circle and  $\text{arc}(AXB) = \frac{1}{2} \text{arc}(BYC)$ . Find  $\angle BOC$ .

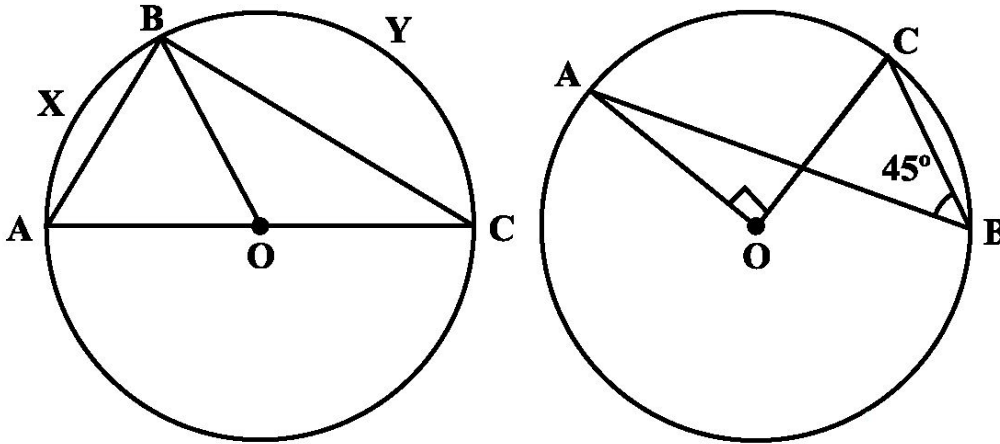

80. In the above right sided figure,  $\angle ABC = 45^\circ$ , prove that  $OA \perp OC$ .

81. Two chords AB and AC of a circle subtends angles equal to  $90^\circ$  and  $150^\circ$ , respectively at the centre. Find  $\angle BAC$ , if AB and AC lie on the opposite sides of the centre.

82. If BM and CN are the perpendiculars drawn on the sides AC and AB of the triangle ABC, prove that the points B, C, M and N are concyclic.

83. If a line is drawn parallel to the base of an isosceles triangle to intersect its equal sides, prove that the quadrilateral so formed is cyclic.

84. If a pair of opposite sides of a cyclic quadrilateral are equal, prove that its diagonals are also equal.

85. The circumcentre of the triangle ABC is O. Prove that  $\angle OBC + \angle BAC = 90^\circ$ .

86. A chord of a circle is equal to its radius. Find the angle subtended by this chord at a point in major segment.

87. In the below figure,  $\angle ADC = 130^\circ$  and chord  $BC = \text{chord } BE$ . Find  $\angle CBE$ .

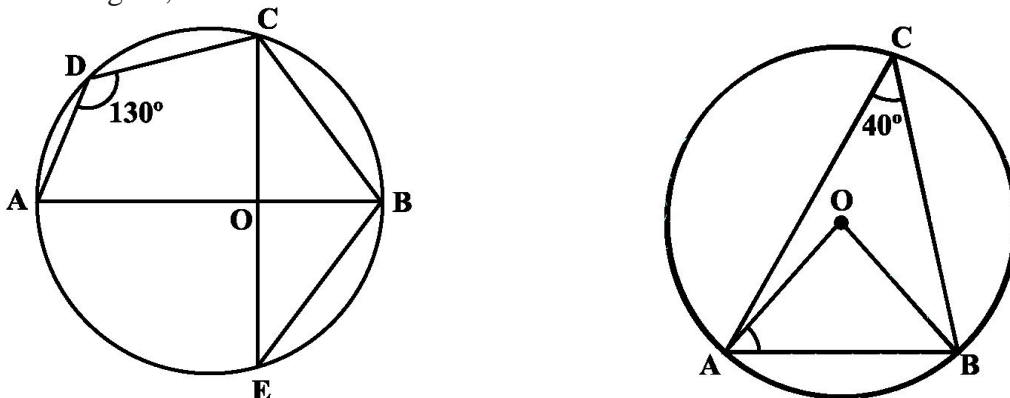

88. In the above right sided figure,  $\angle ACB = 40^\circ$ . Find  $\angle OAB$ .

89. A quadrilateral ABCD is inscribed in a circle such that AB is a diameter and  $\angle ADC = 130^\circ$ . Find  $\angle BAC$ .

90. Two circles with centres O and O' intersect at two points A and B. A line PQ is drawn parallel to OO' through A(or B) intersecting the circles at P and Q. Prove that  $PQ = 2 OO'$

91. In the below figure, AOB is a diameter of the circle and C, D, E are any three points on the semi-circle. Find the value of  $\angle ACD + \angle BED$ .

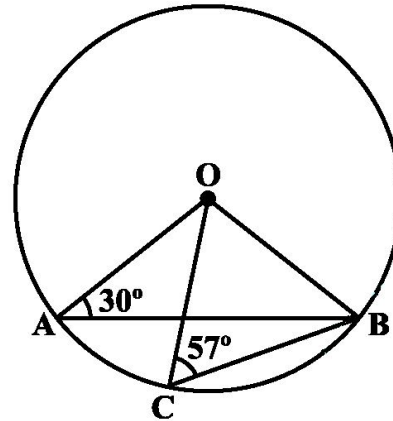
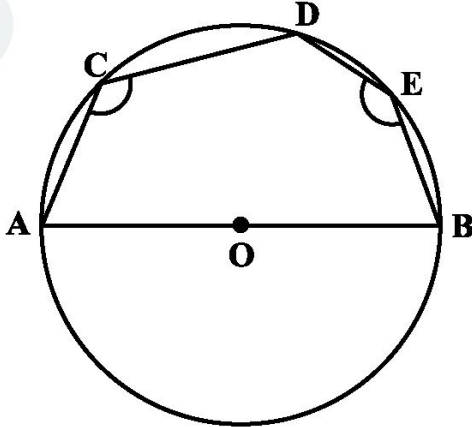

92. In the above right sided figure,  $\angle OAB = 30^\circ$  and  $\angle OCB = 57^\circ$ . Find  $\angle BOC$  and  $\angle AOC$ .

93. In the below figure, O is the centre of the circle,  $\angle BCO = 30^\circ$ , find x and y.

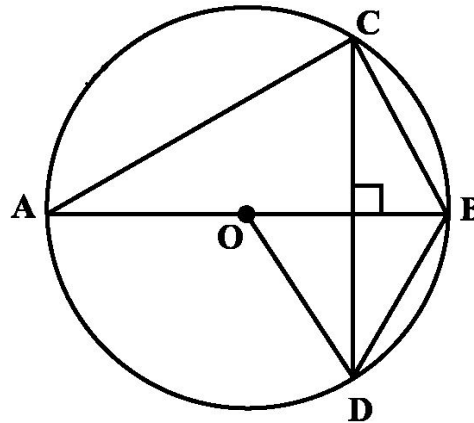
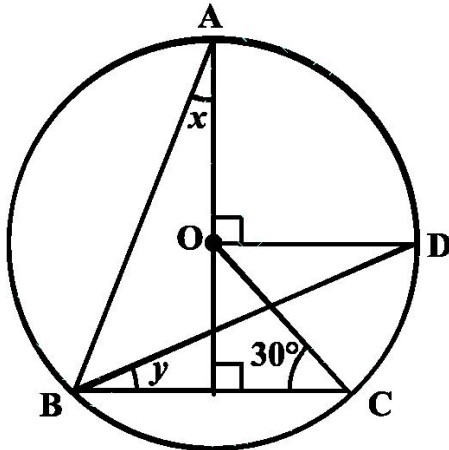

94. In the above right sided figure, O is the centre of the circle,  $BD = OD$  and  $CD \perp AB$ . Find  $\angle CAB$ .

95. Let the vertex of an angle ABC be located outside a circle and let the sides of the angle intersect equal chords AD and CE with the circle. Prove that  $\angle ABC$  is equal to half the difference of the angles subtended by the chords AC and DE at the centre.





**MCQ WORKSHEET-I**  
**CLASS IX: CHAPTER – 11**  
**CONSTRUCTIONS**

1. In a pair of set, squares, one if with angles are  
(a)  $30^{\circ}$ ,  $60^{\circ}$ ,  $90^{\circ}$  (b)  $30^{\circ}$ ,  $30^{\circ}$ ,  $45^{\circ}$  (c)  $75^{\circ}$ ,  $25^{\circ}$ ,  $80^{\circ}$  (d)  $65^{\circ}$ ,  $15^{\circ}$ ,  $100^{\circ}$
2. In a pair of set, squares, the other is with angles  
(a)  $45^{\circ}$ ,  $45^{\circ}$ ,  $90^{\circ}$  (b)  $30^{\circ}$ ,  $50^{\circ}$ ,  $100^{\circ}$  (c)  $60^{\circ}$ ,  $60^{\circ}$ ,  $60^{\circ}$  (d) none of these
3. To draw the perpendicular bisector of line segment AB, we open the compass  
(a) more than  $\frac{1}{2}$  AB (b) less than  $\frac{1}{2}$  AB (c) equal to  $\frac{1}{2}$  AB (d) none of these
4. To construct an angle of  $22\frac{1}{2}^{\circ}$ , we  
(a) bisect an angle of  $60^{\circ}$  (b) bisect an angle of  $30^{\circ}$   
(c) bisect an angle of  $45^{\circ}$  (d) none of these
5. To construct a triangle we must know at least its \_\_\_\_\_ parts.  
(a) two (b) three (c) one (d) five
6. For which of the following condition the construction of a triangle is not possible:  
(a) If two sides and angle included between them is not given  
(b) If two sides and angle included between them is not given  
(c) If its three sides are given  
(d) If two angles and side included between them is given
7. Construction of a triangle is not possible if:  
(a)  $AB + BC < AC$  (b)  $AB + BC = AC$  (c) both (a) and (b) (d)  $AB + BC > AC$
8. With the help of ruler and compass it is not possible to construct an angle of  
(a)  $37.5^{\circ}$  (b)  $40.5^{\circ}$  (c)  $22.5^{\circ}$  (d)  $67.5^{\circ}$
9. The construction of a triangle ABC given that  $BC = 3$  cm,  $\angle C = 60^{\circ}$  is possible when difference of AB and AC is equal to  
(a) 3.2 cm (b) 3.1 cm (c) 3 cm (d) 2.8 cm
10. The construction of a triangle ABC, given that  $BC = 6$ cm,  $\angle = 45^{\circ}$  is not possible when the difference of AB and AC is equal to  
(a) 6.9 cm (b) 5.2 cm (c) 5.0 cm (d) 4.0 cm.
11. Construction of a triangle is not possible if:  
(a)  $AB - BC < AC$  (b)  $AB - BC = AC$  (c) both (a) and (b) (d)  $AB - BC > AC$
12. To construct an angle of  $15^{\circ}$ , we  
(a) bisect an angle of  $60^{\circ}$  (b) bisect an angle of  $30^{\circ}$   
(c) bisect an angle of  $45^{\circ}$  (d) none of these



**PRACTICE QUESTIONS**  
**CLASS IX: CHAPTER – 11**  
**CONSTRUCTIONS**

1. Construct the following angles with the help of ruler and compass, if possible –  
 $35^{\circ}$ ,  $40^{\circ}$ ,  $57^{\circ}$ ,  $75^{\circ}$ ,  $15^{\circ}$ ,  $135^{\circ}$ .
2. Draw a  $\Delta ABC$ , in which  $AB = 4\text{cm}$ ,  $\angle A = 60^{\circ}$  and  $BC - AC = 115\text{ cm}$ .
3. Draw a  $\Delta ABC$ , in which  $BC = 5\text{cm}$ ,  $\angle B = 60^{\circ}$  and  $AC + AB = 7.5\text{ cm}$ .
4. Draw a equilateral triangle whose altitude is 6 cm.
5. Draw a triangle ABC whose perimeter is 10.4 cm and the base angle are  $45^{\circ}$  and  $60^{\circ}$ .
6. Construct a triangle ABC, in which  $\angle B = 60^{\circ}$ ,  $\angle C = 45^{\circ}$  and  $AB + BC + CA = 11\text{ cm}$ .
7. Construct a triangle ABC in which  $BC = 7\text{cm}$ ,  $\angle B = 75^{\circ}$  and  $AB + AC = 13\text{ cm}$ .
8. Construct a triangle ABC in which  $BC = 8\text{cm}$ ,  $\angle B = 45^{\circ}$  and  $AB - AC = 3.5\text{ cm}$ .
9. Construct a triangle PQR in which  $QR = 6\text{cm}$ ,  $\angle Q = 60^{\circ}$  and  $PR - PQ = 2\text{cm}$ .
10. Construct a triangle XYZ in which  $\angle Y = 30^{\circ}$ ,  $\angle Z = 90^{\circ}$  and  $XY + YZ + ZX = 11\text{ cm}$ .
11. Construct a right triangle whose base is 12cm and sum of its hypotenuse and other side is 18 cm.
12. Construct a triangle ABC in which  $BC = 3\text{cm}$ ,  $\angle B = 30^{\circ}$  and  $AB + AC = 5.2\text{ cm}$ .
13. Construct a triangle ABC in which  $BC = 6\text{cm}$ ,  $\angle B = 60^{\circ}$  and the sum of other two sides is 9cm.
14. Construct a triangle ABC in which  $BC = 5.6\text{cm}$ ,  $\angle B = 30^{\circ}$  and the difference between the other two sides is 3 cm.
15. Construct a triangle ABC whose perimeter is 14 cm and the sides are in ratio 2 : 3 : 4.
16. Construct a triangle ABC in which  $BC = 7.5\text{ cm}$ ,  $\angle B = 45^{\circ}$  and  $AB - AC = 4\text{ cm}$ .
17. Construct a square of side 3 cm.
18. Construct a rectangle whose adjacent sides are of lengths 5 cm and 3.5 cm.
19. Construct a rhombus whose side is of length 3.4 cm and one of its angles is  $45^{\circ}$ .
20. Construct a triangle if its perimeter is 10.4 cm and two angles are  $45^{\circ}$  and  $120^{\circ}$ .
21. Construct a triangle PQR given that  $QR = 3\text{cm}$ ,  $\angle PQR = 45^{\circ}$  and  $QP - PR = 2\text{ cm}$ .
22. Construct a right triangle when one side is 3.5 cm and sum of other sides and the hypotenuse is 5.5 cm.
23. Construct an equilateral triangle if its altitude is 3.2 cm.
24. Construct a rhombus whose diagonals are 4 cm and 6 cm in lengths.

**MCQ WORKSHEET-I**  
**CLASS IX: CHAPTER – 13**  
**SURFACE AREAS AND VOLUMES**

1. The surface area of a cuboid is  
(a)  $2(lb + bh + lh)$       (b)  $3(lb + bh + lh)$       (c)  $2(lb - bh - lh)$       (d)  $3(lb - bh - lh)$
2. The surface area of a cube if edge 'a' is  
(a)  $7a^2$       (b)  $6a^2$       (c)  $5a^3$       (d)  $5a^2$
3. The length, breadth and height of a room is 5m, 4m and 3m. The cost of white washing its four walls at the rate of Rs. 7.50 per  $m^2$  is  
(a) Rs. 110      (b) Rs. 109      (c) Rs. 220      (d) Rs. 105
4. The perimeter of floor of rectangular hall is 250m. The cost of the white washing its four walls is Rs. 15000. The height of the room is  
(a) 5m      (b) 4m      (c) 6m      (d) 8m
5. The breadth of a room is twice its height and is half of its length. The volume of room is  $512dm^3$ . Its dimensions are  
(a) 16 dm, 8 dm, 4 dm      (b) 12 dm, 8 dm, 2 dm  
(c) 8 dm, 4 dm, 2 dm      (d) 10 dm, 15 dm, 20 dm
6. The area of three adjacent faces of a cube is x, y and z. Its volume V is  
(a)  $V = xyz$       (b)  $V^3 = xyz$       (c)  $V^2 = xyz$       (d) none of these
7. Two cubes each of edge 12 cm are joined. The surface area of new cuboid is  
(a)  $140 cm^2$       (b)  $1440 cm^2$       (c)  $144 cm^2$       (d)  $72 cm^2$
8. The curved surface area of cylinder of height 'h' and base radius 'r' is  
(a)  $2\pi rh$       (b)  $\pi rh$       (c)  $\frac{1}{2}\pi rh$       (d) none of these
9. The total surface area of cylinder of base radius 'r' and height 'h' is  
(a)  $2\pi(r + h)$       (b)  $2\pi r(r + h)$       (c)  $3\pi r(r + h)$       (d)  $4\pi r(r + h)$
10. The curved surface area of a cylinder of height 14 cm is  $88 cm^2$ . The diameter of its circular base is  
(a) 5cm      (b) 4cm      (c) 3cm      (d) 2cm
11. It is required to make a closed cylindrical tank of height 1 m and base diameter 140cm from a metal sheet. How many square meters a sheet are required for the same?  
(a)  $6.45m^2$       (b)  $6.48m^2$       (c)  $7.48m^2$       (d)  $5.48m^2$ .
12. A metal pipe is 77 cm long. Inner diameter of cross section is 4 cm and outer diameter is 4.4 cm. Its inner curved surface area is:  
(a)  $864 cm^2$       (b)  $968 cm^2$       (c)  $768 cm^2$       (d) none of these

**MCQ WORKSHEET-II**  
**CLASS IX: CHAPTER – 13**  
**SURFACE AREAS AND VOLUMES**

1. The diameter of a roller is 84 cm and its length is 120 cm. It takes 500 complete revolutions to move once over to level a playground. The area of the playground in  $m^2$  is:  
(a) 1584      (b) 1284      (c) 1384      (d) 1184
2. A cylindrical pillar is 50 cm in diameter and 3.5 m in height. The cost of painting its curved surface at the rate of Rs. 12.50 per  $m^2$  is:  
(a) Rs. 68.75   (b) Rs. 58.75   (c) Rs. 48.75   (d) Rs. 38.75
3. The inner diameter of circular well is 3.5m. It is 10m deep. Its inner curved surface area in  $m^2$  is:  
(a) 120      (b) 110      (c) 130      (d) 140
4. In a hot water heating system there is a cylindrical pipe of length 28 m and diameter 5 cm. The total radiating surface area in the system in  $m^2$  is:  
(a) 6.6      (b) 5.5      (c) 4.4      (d) 3.4
5. The curved surface area of a right circular cone of slant height 10 cm and base radius 7 cm is  
(a)  $120\text{ cm}^2$    (b)  $220\text{ cm}^2$    (c)  $240\text{ cm}^2$       (d)  $140\text{ cm}^2$
6. The height of a cone is 16 cm and base radius is 12 cm. Its slant height is  
(a) 10 cm      (b) 15 cm      (c) 20 cm      (d) 8 cm
7. The curved surface area of a right circular cone of height 16 cm and base radius 12 cm is  
(a)  $753.6\text{ cm}^2$    (b)  $1205.76\text{ cm}^2$       (c)  $863.8\text{ cm}^2$       (d)  $907.6\text{ cm}^2$
8. The curved surface area of a right circular cone of slant height 10 cm and base radius 10.5 cm is  
(a)  $185\text{ cm}^2$    (b)  $160\text{ cm}^2$    (c)  $165\text{ cm}^2$       (d)  $195\text{ cm}^2$
9. The slant height of a cone is 26 cm and base diameter is 20 cm. Its height is  
(a) 24 cm      (b) 25 cm      (c) 23 cm      (d) 35 cm
10. The curved surface area of a cone is  $308\text{ cm}^2$  and its slant height is 14 cm. The radius of its base is  
(a) 8 cm      (b) 7 cm      (c) 9 cm      (d) 12 cm
11. A conical tent is 10 m high and the radius of its base is 24 m. The slant height of tent is  
(a) 26 m      (b) 28 m      (c) 25 m      (d) 27 m
12. The slant height and base diameter of a conical tomb are 25 m and 14 m respectively. The cost of white washing its curved surface at the rate of Rs. 210 per  $100\text{ m}^2$  is  
(a) Rs. 1233   (b) Rs. 1155   (c) Rs. 1388   (d) Rs. 1432

**MCQ WORKSHEET-III**  
**CLASS IX: CHAPTER – 13**  
**SURFACE AREAS AND VOLUMES**

1. A joker's cap is in the form of cone of base radius 7 cm and height 24 cm. The area of sheet to make 10 such caps is  
(a)  $5500 \text{ cm}^2$  (b)  $6500 \text{ cm}^2$  (c)  $8500 \text{ cm}^2$  (d)  $3500 \text{ cm}^2$
2. The curved surface area of a hemisphere of radius 'r' is  
(a)  $2\pi r^2$  (b)  $4\pi r^2$  (c)  $3\pi r^2$  (d)  $5\pi r^2$
3. The total surface area of a hemisphere of radius 'r' is  
(a)  $2\pi r^2$  (b)  $4\pi r^2$  (c)  $3\pi r^2$  (d)  $5\pi r^2$
4. The curved surface area of a sphere of radius 7 cm is:  
(a)  $516 \text{ cm}^2$  (b)  $616 \text{ cm}^2$  (c)  $716 \text{ cm}^2$  (d)  $880 \text{ cm}^2$
5. The curved surface area of a hemisphere of radius 21 cm is:  
(a)  $2772 \text{ cm}^2$  (b)  $2564 \text{ cm}^2$  (c)  $3772 \text{ cm}^2$  (d)  $4772 \text{ cm}^2$
6. The curved surface area of a sphere of radius 14 cm is:  
(a)  $2464 \text{ cm}^2$  (b)  $2428 \text{ cm}^2$  (c)  $2464 \text{ cm}^2$  (d) none of these.
7. The curved surface area of a sphere of diameter 14 cm is:  
(a)  $516 \text{ cm}^2$  (b)  $616 \text{ cm}^2$  (c)  $716 \text{ cm}^2$  (d)  $880 \text{ cm}^2$
8. Total surface area of hemisphere of radius 10 cm is  
(a)  $942 \text{ cm}^2$  (b)  $940 \text{ cm}^2$  (c)  $842 \text{ cm}^2$  (d)  $840 \text{ cm}^2$
9. The radius of a spherical balloon increases from 7 cm to 14 cm as air is being pumped into it. The ratio of surface area of the balloon in the two cases is:  
(a) 4 : 1 (b) 1 : 4 (c) 3 : 1 (d) 1 : 3
10. A matchbox measures 4 cm x 2.5 cm x 1.5 cm. The volume of packet containing 12 such boxes is:  
(a)  $160 \text{ cm}^3$  (b)  $180 \text{ cm}^3$  (c)  $160 \text{ cm}^2$  (d)  $180 \text{ cm}^2$
11. A cuboidal water tank is 6 m long, 5 m wide and 4.5 m deep. How many litre of water can it hold?  
(a) 1350 liters (b) 13500 liters (c) 135000 liters (d) 135 liters
12. A cuboidal vessel is 10 m long and 8 m wide. How high must it be made to hold 380 cubic metres of a liquid?  
(a) 4.75 m (b) 7.85 m (c) 4.75 cm (d) none of these
13. The capacity of a cuboidal tank is 50000 litres. The length and depth are respectively 2.5 m and 10 m. Its breadth is  
(a) 4 m (b) 3 m (c) 2 m (d) 5 m
14. A godown measures  $40 \text{ m} \times 25 \text{ m} \times 10 \text{ m}$ . Find the maximum number of wooden crates each measuring  $1.5 \text{ m} \times 1.25 \text{ m} \times 0.5 \text{ m}$  that can be stored in the godown.  
(a) 18000 (b) 16000 (c) 15000 (d) 14000

**MCQ WORKSHEET-IV**  
**CLASS IX: CHAPTER – 13**  
**SURFACE AREAS AND VOLUMES**

1. A river 3 m deep and 40 m wide is flowing at the rate of 2 km per hour. How much water will fall into the sea in a minute?  
(a)  $4000 \text{ m}^3$     (b)  $40 \text{ m}^3$     (c)  $400 \text{ m}^3$     (d)  $40000 \text{ m}^3$
  2. The circumference of the base of a cylindrical vessel is 132 cm and its height is 25 cm. How many litres of water can it hold?  
(a) 33.75 litre    (b) 34.65 litre    (c) 35.75 litre    (d) 38.75 litre
  3. If the lateral surface of a cylinder is  $94.2 \text{ cm}^2$  and its height is 5 cm, then find radius of its base  
(a) 5cm    (b) 4cm    (c) 3cm    (d) 6cm
  4. It costs Rs 2200 to paint the inner curved surface of a cylindrical vessel 10 m deep. If the cost of painting is at the rate of Rs 20 per  $\text{m}^2$ , find radius of the base,  
(a) 1.75 m    (b) 1.85 m    (c) 1.95 m    (d) 1.65 m
  5. The height and the slant height of a cone are 21 cm and 28 cm respectively. Find the volume of the cone.  
(a)  $5546 \text{ cm}^3$     (b)  $7546 \text{ cm}^3$     (c)  $5564 \text{ m}^3$     (d)  $8546 \text{ cm}^3$
  6. Find the volume of the right circular cone with radius 6 cm, height 7 cm  
(a)  $254 \text{ cm}^3$     (b)  $264 \text{ cm}^3$     (c)  $274 \text{ cm}^2$     (d)  $284 \text{ cm}^3$
  7. The radius and height of a conical vessel are 7 cm and 25 cm respectively. Its capacity in litres is  
(a) 1.232 litre    (b) 1.5 litre    (c) 1.35 litre    (d) 1.6 litre
  8. The height of a cone is 15 cm. If its volume is  $1570 \text{ cm}^3$ , find the radius of the base.  
(a) 12 cm    (b) 10 cm    (c) 15 cm    (d) 18 cm
  9. If the volume of a right circular cone of height 9 cm is  $48\pi \text{ cm}^3$ , find the diameter of its base.  
(a) 12 cm    (b) 10 cm    (c) 6 cm    (d) 8 cm
  10. A conical pit of top diameter 3.5 m is 12 m deep. What is its capacity in kilolitres?  
(a) 38.5 kl    (b) 48.5 kl    (c) 39.5 kl    (d) 47.5 kl
  11. Find the capacity in litres of a conical vessel with radius 7 cm, slant height 25 cm  
(a) 1.232 litre    (b) 1.5 litre    (c) 1.35 litre    (d) none of these
  12. The diameter of the moon is approximately one-fourth of the diameter of the earth. What fraction of the volume of the earth is the volume of the moon?  
(a)  $\frac{1}{64}$     (b)  $\frac{1}{32}$     (c)  $\frac{1}{16}$     (d)  $\frac{1}{48}$
  13. The dimensions of a cuboid are 50 cm x 40 cm x 10 cm. Its volume in litres is:  
(a) 10 litres    (b) 12 litres    (c) 20 litres    (d) 25 litres
  14. The volume of a cuboidal tank is  $250 \text{ m}^3$ . If its base area is  $50 \text{ m}^2$  then depth of the tank is  
(a) 5 m    (b) 200 m    (c) 300 m    (d) 12500 m
- .....

**MCQ WORKSHEET-V**  
**CLASS IX: CHAPTER – 13**  
**SURFACE AREAS AND VOLUMES**

1. The length, breadth and height of a cuboidal solid is 4 cm, 3 cm and 2 cm respectively. Its volume is  
(a)  $(4 + 3 + 2) \text{ cm}^3$     (b)  $2(4 + 3 + 2) \text{ cm}^3$     (c)  $(4 \times 3 \times 2) \text{ cm}^3$     (d)  $2(4 + 3) \times 2 \text{ cm}^3$
  2. The volume of a cuboidal solid of length 8 m and breadth 5 m is  $200 \text{ m}^3$ . Find its height.  
(a) 5 m    (b) 6 m    (c) 15 m    (d) 18 m
  3. The curved surface area of a sphere is  $616 \text{ cm}^2$ . Its radius is  
(a) 7 cm    (b) 5 cm    (c) 6 cm    (d) 8 cm
  4. If radius of a sphere is  $\frac{2d}{3}$  then its volume is  
(a)  $\frac{32}{81} \pi d^3$     (b)  $\frac{23}{4} \pi d^3$     (c)  $\frac{32}{3} \pi d^3$     (d)  $\frac{34}{3} \pi d^3$
  5. The capacity of a cylindrical tank is  $6160 \text{ cm}^3$ . Its base diameter is 28 m. The depth of this tank is  
(a) 5 m    (b) 10 m    (c) 15 m    (d) 8 m
  6. The volume of a cylinder of radius r and length h is:  
(a)  $2\pi rh$     (b)  $\frac{4}{3} \pi r^2 h$     (c)  $\pi r^2 h$     (d)  $2\pi r^2 h$
  7. Base radius of two cylinder are in the ratio 2 : 3 and their heights are in the ratio 5 : 3. The ratio of their volumes is  
(a) 27 : 20    (b) 25 : 24    (c) 20 : 27    (d) 15 : 20
  8. If base radius and height of a cylinder are increased by 100% then its volume increased by:  
(a) 30%    (b) 40%    (c) 42%    (d) 33.1%
  9. The diameter of a sphere is 14 m. The volume of this sphere is  
(a)  $1437\frac{1}{3} \text{ m}^3$     (b)  $1357\frac{1}{3} \text{ m}^3$     (c)  $1437\frac{2}{3} \text{ m}^3$     (d)  $1337\frac{2}{3} \text{ m}^3$
  10. The volume of a sphere is  $524 \text{ cm}^3$ . The diameter of sphere is  
(a) 5cm    (b) 4cm    (c) 3cm    (d) 7cm
  11. The total surface area of a cylinder is  $40\pi \text{ cm}^2$ . If height is 5.5 cm then its base radius is  
(a) 5cm    (b) 2.5cm    (c) 1.5cm    (d) 10cm
  12. The area of circular base of a right circular cone is  $78.5 \text{ cm}^2$ . If its height is 12 cm then its volume is  
(a)  $31.4 \text{ cm}^3$     (b)  $3.14 \text{ cm}^3$     (c)  $314 \text{ cm}^3$     (d) none of these
  13. The base radius of a cone is 11.3 cm and curved surface area is  $355 \text{ cm}^2$ . Its height is (Take  $\pi = \frac{355}{113}$ )  
(a) 5 cm    (b) 10 cm    (c) 11 cm    (d) 9 cm
- .....

**MCQ WORKSHEET-VI**  
**CLASS IX: CHAPTER – 13**  
**SURFACE AREAS AND VOLUMES**

1. If the dimensions of a cuboid are 3 cm, 4 cm and 10 cm, then its surface area is  
A.  $82 \text{ cm}^2$       B.  $123 \text{ cm}^2$       C.  $164 \text{ cm}^2$       D.  $216 \text{ cm}^2$
2. The volume of the cuboid in Q.1 is  
A.  $17 \text{ cm}^3$       B.  $164 \text{ cm}^3$       C.  $120 \text{ cm}^3$       D.  $240 \text{ cm}^3$
3. The surface area of a cuboid is 1372 sq. cm. If its dimensions are in the ratio of 4 : 2 : 1, then its length is  
A. 7 cm      B. 14 cm      C. 21 cm      D. 28cm
4. The base radius and height of a right circular cylinder are 7 cm and 13.5 cm. The volume of cylinder is  
A.  $1579 \text{ cm}^3$       B.  $1897 \text{ cm}^3$       C.  $2079 \text{ cm}^3$       D.  $2197 \text{ cm}^3$
5. The base radius of a cone is 5 cm and its height is 12 cm. Its slant height is  
A. 13 cm      B. 19.5 cm      C. 26 cm      D. 52cm
6. The curved surface area of a cylinder of height 14 cm is 88 sq. cm. The diameter of the cylinder is  
A. 0.5 cm      B. 1.0 cm      C. 1.5 cm      D. 2.0 cm
7. The lateral surface area of a right circular cone of height 28 cm and base radius 21 cm is  
A.  $1155 \text{ cm}^2$       B.  $1055 \text{ cm}^2$       C.  $2110 \text{ cm}^2$       D.  $2310 \text{ cm}^2$
8. The circumference of the base of a 8 m high conical tent is  $\frac{264}{7} \text{ m}^2$ . The area of canvas required to make the tent is  
A.  $\frac{1360}{7} \text{ cm}^2$       B.  $\frac{1360}{14} \text{ cm}^2$       C.  $286 \text{ cm}^2$       D.  $98 \text{ cm}^2$
9. The area of metal sheet required to make a closed hollow cone of height 24 m and base radius 7 m is  
A.  $176 \text{ m}^2$       B.  $352 \text{ m}^2$       C.  $704 \text{ m}^2$       D.  $1408 \text{ m}^2$
10. The diameter of a sphere whose surface area is  $346.5 \text{ cm}^2$  is  
A. 5.25 cm      B. 5.75 cm      C. 11.5 cm      D. 10.5 cm
11. The radius of a spherical baloon increases from 7 cm to 14 cm when air is pumped into it. The ratio of the surface area of original baloon to inflated one is  
A. 1 : 2      B. 1 : 3      C. 1 : 4      D. 4 : 3

12. The circumference of the base of a cylindrical vessel is 132 cm and its height is 25 cm. If 1000 cu.cm = 1 liter, the number of litres, of water the vessel can hold is
- A. 17.325                  B. 34.65                  C. 34.5                  D. 69.30
13. The number of litres of milk a hemispherical bowl of radius 10.5 cm can hold is
- A. 2.47                  B. 2.476                  C. 2.376                  D. 3.476
14. The number of bricks, each measuring 18 cm × 12 cm × 10 cm are required to build a 1 wall 12 m × 0.6 m × 4.5 m if  $\frac{1}{10}$  of its volume is taken by mortar, is
- A. 15000                  B. 13500                  C. 12500                  D. 13900
15. The radius of a sphere is 10 cm. If its radius is increased by 1 cm, the volume of the sphere is increased by
- A. 13.3%                  B. 21.1%                  C. 30%                  D. 33.1%
- .....



**PRACTICE QUESTIONS**  
**CLASS IX: CHAPTER – 13**  
**SURFACE AREAS AND VOLUMES**

1. The dimensions of a prayer Hall are 20m x 15m x 8m. Find the cost of painting its walls at Rs. 10 per m<sup>2</sup>.
2. Find the curved surface area of a right circular cylinder whose height is 13.5 cm and radius of its base is 7 cm. Find also its surface area.
3. The exterior diameter of an iron pipe is 25cm and it is one cm thick. Find the whole surface area of the pipe if it is 21cm long.
4. A roller 150 cm long has a diameter of 70 cm. To level a playground it takes 750 complete revolutions. Determine the cost of leveling the playground at the rate of 75 paise per m<sup>2</sup>.
5. Find the total surface area of a cone, if its slant height is 21 cm and the diameter of its base is 24 cm.
6. The volume of a sphere is 4851 cm<sup>3</sup>. How much should its radius be reduced so that its volume becomes  $\frac{4312}{3}$  cm<sup>3</sup>.
7. A river, 3 m deep and 40m wide, is flowing at the rate of 2km/hr. How much water will fall into the sea in a minute?
8. Find the capacity in litres of a conical vessel whose diameter is 14 cm and slant height is 25 cm.
9. What is the total surface area of a hemisphere of base radius 7cm?
10. A village having a population of 4000, requires 150 litres of water per head per day. It has a tank measuring 20m x 15m x 6m. For how many days, the water of the tank will be sufficient for the village?
11. Mary wants to decorate her Christmas tree. She wants to place the tree on a wooden box covered with coloured paper with picture of Santa Claus on it. She must know the exact quantity of paper to buy for this purpose. If the box has length, breadth and height as 80 cm, 40 cm and 20 cm respectively how many square sheets of paper of side 40 cm would she require?
12. Hameed has built a cubical water tank with lid for his house, with each outer edge 1.5 m long. He gets the outer surface of the tank excluding the base, covered with square tiles of side 25 cm. Find how much he would spend for the tiles, if the cost of the tiles is Rs 360 per dozen.
13. A small indoor greenhouse (herbarium) is made entirely of glass panes (including base) held together with tape. It is 30 cm long, 25 cm wide and 25 cm high. (i) What is the area of the glass? (ii) How much of tape is needed for all the 12 edges?
14. Shanti Sweets Stall was placing an order for making cardboard boxes for packing their sweets. Two sizes of boxes were required. The bigger of dimensions 25 cm × 20 cm × 5 cm and the smaller of dimensions 15 cm × 12 cm × 5 cm. For all the overlaps, 5% of the total surface area is required extra. If the cost of the cardboard is Rs 4 for 1000 cm<sup>2</sup>, find the cost of cardboard required for supplying 250 boxes of each kind.

15. Parveen wanted to make a temporary shelter for her car, by making a box-like structure with tarpaulin that covers all the four sides and the top of the car (with the front face as a flap which can be rolled up). Assuming that the stitching margins are very small, and therefore negligible, how much tarpaulin would be required to make the shelter of height 2.5 m, with base dimensions  $4\text{ m} \times 3\text{ m}$ ?

16. Savitri had to make a model of a cylindrical kaleidoscope for her science project. She wanted to use chart paper to make the curved surface of the kaleidoscope. What would be the area of chart paper required by her, if she wanted to make a kaleidoscope of length 25 cm with a 3.5 cm radius?



17. A metal pipe is 77 cm long. The inner diameter of a cross section is 4 cm, the outer diameter being 4.4 cm. Find its

- (i) inner curved surface area,
- (ii) outer curved surface area,
- (iii) total surface area.

18. Find (i) the lateral or curved surface area of a closed cylindrical petrol storage tank that is 4.2 m in diameter and 4.5 m high. (ii) how much steel was actually used, if  $\frac{1}{12}$  of the steel actually used was wasted in making the tank.

19. Find the curved surface area of a right circular cone whose slant height is 10 cm and base radius is 7 cm.

20. The height of a cone is 16 cm and its base radius is 12 cm. Find the curved surface area and the total surface area of the cone (Use  $\pi = 3.14$ ).

21. A corn cob shaped somewhat like a cone, has the radius of its broadest end as 2.1 cm and length (height) as 20 cm. If each  $1\text{ cm}^2$  of the surface of the cob carries an average of four grains, find how many grains you would find on the entire cob.

22. In the adjoining figure you see the frame of a lampshade. It is to be covered with a decorative cloth. The frame has a base diameter of 20 cm and height of 30 cm. A margin of 2.5 cm is to be given for folding it over the top and bottom of the frame. Find how much cloth is required for covering the lampshade.

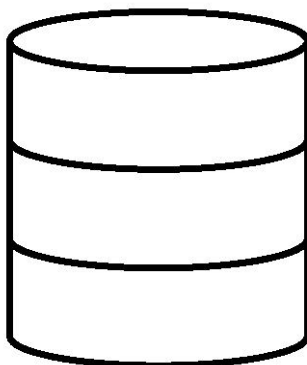

23. A conical tent is 10 m high and the radius of its base is 24 m. Find (i) slant height of the tent. (ii) cost of the canvas required to make the tent, if the cost of  $1\text{ m}^2$  canvas is Rs 70.

24. What length of tarpaulin 3 m wide will be required to make conical tent of height 8 m and base radius 6 m? Assume that the extra length of material that will be required for stitching margins and wastage in cutting is approximately 20 cm (Use  $\pi = 3.14$ ).
25. The slant height and base diameter of a conical tomb are 25 m and 14 m respectively. Find the cost of white-washing its curved surface at the rate of Rs 210 per 100 m<sup>2</sup>.
26. A joker's cap is in the form of a right circular cone of base radius 7 cm and height 24 cm. Find the area of the sheet required to make 10 such caps.
27. A hemispherical dome of a building needs to be painted. If the circumference of the base of the dome is 17.6 m, find the cost of painting it, given the cost of painting is Rs 5 per 100 cm<sup>2</sup>.
28. A right circular cylinder just encloses a sphere of radius  $r$ . Find (i) surface area of the sphere, (ii) curved surface area of the cylinder, (iii) ratio of the areas obtained in (i) and (ii).

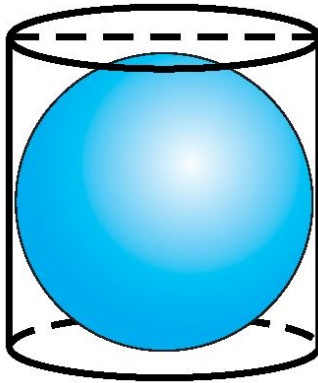

29. A hemispherical bowl is made of steel, 0.25 cm thick. The inner radius of the bowl is 5 cm. Find the outer curved surface area of the bowl.
30. A wall of length 10 m was to be built across an open ground. The height of the wall is 4 m and thickness of the wall is 24 cm. If this wall is to be built up with bricks whose dimensions are 24 cm  $\times$  12 cm  $\times$  8 cm, how many bricks would be required?
31. A village, having a population of 4000, requires 150 litres of water per head per day. It has a tank measuring 20 m  $\times$  15 m  $\times$  6 m. For how many days will the water of this tank last?
32. A godown measures 40 m  $\times$  25 m  $\times$  10 m. Find the maximum number of wooden crates each measuring 1.5 m  $\times$  1.25 m  $\times$  0.5 m that can be stored in the godown.
33. A solid cube of side 12 cm is cut into eight cubes of equal volume. What will be the side of the new cube? Also, find the ratio between their surface areas.
34. A river 3 m deep and 40 m wide is flowing at the rate of 2 km per hour. How much water will fall into the sea in a minute?
35. The capacity of a closed cylindrical vessel of height 1 m is 15.4 litres. How many square metres of metal sheet would be needed to make it?
36. A lead pencil consists of a cylinder of wood with a solid cylinder of graphite filled in the interior. The diameter of the pencil is 7 mm and the diameter of the graphite is 1 mm. If the length of the pencil is 14 cm, find the volume of the wood and that of the graphite.

37. The pillars of a temple are cylindrically shaped. If each pillar has a circular base of radius 20 cm and height 10 m, how much concrete mixture would be required to build 14 such
38. Monica has a piece of canvas whose area is 551 m<sup>2</sup>. She uses it to have a conical tent made, with a base radius of 7 m. Assuming that all the stitching margins and the wastage incurred while cutting, amounts to approximately 1 m<sup>2</sup>, find the volume of the tent that can be made with it.
39. A right triangle ABC with sides 5 cm, 12 cm and 13 cm is revolved about the side 12 cm. Find the volume of the solid so obtained.
40. A heap of wheat is in the form of a cone whose diameter is 10.5 m and height is 3 m. Find its volume. The heap is to be covered by canvas to protect it from rain. Find the area of the canvas required.
41. A dome of a building is in the form of a hemisphere. From inside, it was white-washed at the cost of Rs 498.96. If the cost of white-washing is Rs 2.00 per square metre, find the (i) inside surface area of the dome, (ii) volume of the air inside the dome.
42. Twenty seven solid iron spheres, each of radius  $r$  and surface area  $S$  are melted to form a sphere with surface area  $S'$ . Find the (i) radius  $r'$  of the new sphere, (ii) ratio of  $S$  and  $S'$ .
43. A capsule of medicine is in the shape of a sphere of diameter 3.5 mm. How much medicine (in mm<sup>3</sup>) is needed to fill this capsule?
44. The surface area of a sphere of radius 5 cm is five times the area of the curved surface of a cone of radius 4 cm. Find the height and the volume of the cone (taking  $\pi = \frac{22}{7}$ )
45. The radius of a sphere is increased by 10%. Prove that the volume will be increased by 33.1% approximately.
46. Metal spheres, each of radius 2 cm, are packed into a rectangular box of internal dimensions 16 cm  $\times$  8 cm  $\times$  8 cm. When 16 spheres are packed the box is filled with preservative liquid. Find the volume of this liquid. Give your answer to the nearest integer. [Use  $\pi = 3.14$ ]
47. A storage tank is in the form of a cube. When it is full of water, the volume of water is 15.625 m<sup>3</sup>. If the present depth of water is 1.3 m, find the volume of water already used from the tank.
48. Find the amount of water displaced by a solid spherical ball of diameter 4.2 cm, when it is completely immersed in water.
49. How many square metres of canvas is required for a conical tent whose height is 3.5 m and the radius of the base is 12 m?
50. Two solid spheres made of the same metal have weights 5920 g and 740 g, respectively. Determine the radius of the larger sphere, if the diameter of the smaller one is 5 cm.
51. A school provides milk to the students daily in a cylindrical glasses of diameter 7 cm. If the glass is filled with milk upto an height of 12 cm, find how many litres of milk is needed to serve 1600 students.
52. A cylindrical roller 2.5 m in length, 1.75 m in radius when rolled on a road was found to cover the area of 5500 m<sup>2</sup>. How many revolutions did it make?

53. A small village, having a population of 5000, requires 75 litres of water per head per day. The village has got an overhead tank of measurement  $40\text{ m} \times 25\text{ m} \times 15\text{ m}$ . For how many days will the water of this tank last?
54. A shopkeeper has one spherical laddoo of radius 5cm. With the same amount of material, how many laddoos of radius 2.5 cm can be made?
55. A right triangle with sides 6 cm, 8 cm and 10 cm is revolved about the side 8 cm. Find the volume and the curved surface of the solid so formed.
56. Rain water which falls on a flat rectangular surface of length 6 m and breadth 4 m is transferred into a cylindrical vessel of internal radius 20 cm. What will be the height of water in the cylindrical vessel if the rain fall is 1 cm. Give your answer to the nearest integer. (Take  $\pi = 3.14$ )
57. A cylindrical tube opened at both the ends is made of iron sheet which is 2 cm thick. If the outer diameter is 16 cm and its length is 100 cm, find how many cubic centimeters of iron has been used in making the tube ?
58. A semi-circular sheet of metal of diameter 28cm is bent to form an open conical cup. Find the capacity of the cup.
59. A cloth having an area of  $165\text{ m}^2$  is shaped into the form of a conical tent of radius 5 m
- How many students can sit in the tent if a student, on an average, occupies  $\frac{5}{7}\text{ m}^2$  on the ground?
  - Find the volume of the cone.
60. The water for a factory is stored in a hemispherical tank whose internal diameter is 14 m. The tank contains 50 kilolitres of water. Water is pumped into the tank to fill to its capacity. Calculate the volume of water pumped into the tank.
61. The volumes of the two spheres are in the ratio 64 : 27. Find the ratio of their surface areas.
62. A cube of side 4 cm contains a sphere touching its sides. Find the volume of the gap in between.
63. A sphere and a right circular cylinder of the same radius have equal volumes. By what percentage does the diameter of the cylinder exceed its height ?
64. 30 circular plates, each of radius 14 cm and thickness 3cm are placed one above the another to form a cylindrical solid. Find : (i) the total surface area (ii) volume of the cylinder so formed.
65. A hemispherical tank is made up of an iron sheet 1 cm thick. If the inner radius is 1 m, then find the volume of the iron used to make the tank.
- .....

**MCQ WORKSHEET-I**  
**CLASS IX: CHAPTER - 14**  
**STATISTICS**

1. Class mark and class size of the class interval are 25 and 10 respectively then the class interval is  
(a) 20 – 30    (b) 30 – 40    (c) 40 – 50    (d) 50 – 60
2. Class mark of the 1<sup>st</sup> class interval is 5 and there are five classes. If the class size is 10 then the last class interval is  
(a) 20 – 30    (b) 30 – 40    (c) 40 – 50    (d) 50 – 60

3. The median of the following data is

x	5	10	15	25	30
f	4	6	7	3	5

- (a) 10            (b) 15            (c) 25            (d) 30
4. The mode in the above frequency distribution table is  
(a) 10            (b) 15            (c) 25            (d) 30

5. The mean of the following data is

x	5	10	15	20	25	30
f	4	5	3	2	3	3

- (a) 15            (b) 16            (c) 17            (d) none of these
6. The median of first ten prime numbers is  
(a) 11            (b) 12            (c) 13            (d) none of these.
7. The mean of first ten multiples of 5 is  
(a) 45            (b) 55            (c) 65            (d) none of these.
8. The mean of first ten multiples of 2 is  
(a) 11            (b) 12            (c) 13            (d) none of these.
9. The median of first ten multiples of 3 is  
(a) 15            (b) 16            (c) 16.5            (d) none of these.

10. The median of the following data is

x	10	20	30	40	50	60
f	4	5	6	7	2	3

- (a) 20            (b) 30            (c) 40            (d) none of these
11. The median of the following data is  
25    72    28    65    29    60    30    54    32    53  
33    52    35    51    42    48    45    47    46    33  
(a) 45            (b) 45.5            (c) 46            (d) none of these

12. Calculate the median income from the following data:

Income (in Rs,	10	20	30	40
No. of persons	2	4	10	4

- (a) 20            (b) 30            (c) 40            (d) none of these

**MCQ WORKSHEET-II**  
**CLASS IX: CHAPTER - 14**  
**STATISTICS**

1. Class mark of class 150 – 160 is  
(a) 150          (b) 160          (c) 155          (d) none of these.
2. Average of numbers: 10, 8, 9, 7, 8 is  
(a) 8.4          (b) 7.4          (c) 4.8          (d) 8.2.
3. Mean of first 10 natural numbers is  
(a) 6.5          (b) 5.5          (c) 7.5          (d) 8.5.
4. The heights (in cm) of 9 students of a class are as follows:  
155, 160, 145, 149, 150, 147, 152, 144, 148  
Find the median of this data.  
(a) 150          (b) 147          (c) 149          (d) 148
5. The points scored by a Kabaddi team in a series of matches are as follows  
17, 2, 7, 27, 15, 5, 14, 8, 10, 24, 48, 10, 8, 7, 18, 28  
Find the median of the points scored by the team.  
(a) 12          (b) 15          (c) 24          (d) 28
6. Find the mode of the following marks (out of 10) obtained by 20 students:  
4, 6, 5, 9, 3, 2, 7, 7, 6, 5, 4, 9, 10, 10, 3, 4, 7, 6, 9, 9  
(a) 4          (b) 7          (c) 10          (d) 9
7. 5 people were asked about the time in a week they spend in doing social work in their community. They said 10, 7, 13, 20 and 15 hours, respectively. Find the mean (or average) time in a week devoted by them for social work.  
(a) 12          (b) 13          (c) 14          (d) none of these.
8. The width of each of five continuous classes in a frequency distribution is 5 and the lower class limit of the lowest class limit of the lowest class is 10. The upper class limit of the highest class is:  
(a) 35          (b) 15          (c) 25          (d) 40
9. Let  $m$  be the midpoint and ' $l$ ' the upper class limit of a class in a continuous frequency distribution. The lower class limit of the class is  
(a)  $2m + l$           (b)  $2m - l$           (c)  $m - l$           (d)  $m - 2l$
10. The class marks of a frequency distribution are given as follows: 15, 20, 25, ..... The class corresponding to the class mark 20 is  
(a) 12.5 – 17.5          (b) 17.5 – 22.5          (c) 22.5 – 27.5          (d) 27.5 – 32.5
11. In the class intervals 10 – 20, 20 – 30, the number 20 is included in.  
(a) 10 – 20          (b) 20 – 30          (c) both the interval          (d) none of these intervals
12. The mean of 5 numbers is 30. If one number is excluded, their mean becomes 28. The excluded number is  
(a) 28          (b) 30          (c) 35          (d) 38.

**MCQ WORKSHEET-III**  
**CLASS IX: CHAPTER - 14**  
**STATISTICS**

1. Class mark of class 150 – 160 is  
(a) 150            (b) 160            (c) 155            (d) none of these.
2. A grouped frequency distribution table with class intervals of equal sizes using 250 – 270 as one of the class interval is constructed for the following data:  
268, 220, 368, 258, 242, 310, 272, 342, 310, 290, 300, 320, 319, 304, 402, 318, 406,  
292, 354, 278, 210, 240, 330, 316, 406, 215, 258, 236  
The frequency of the class 310 – 330 is  
(a) 4            (b) 5            (c) 6            (d) 7.
3. To draw a histogram to represent the following frequency distribution: the adjusted frequency for the class interval 25 – 45 is

C. I.	5 – 10	10 – 15	15 – 25	25 – 45	45 – 75
f	6	12	10	8	15

- (a) 6            (b) 5            (c) 2            (d) 3
4. If the mean of the observations:  $x, x + 3, x + 5, x + 7, x + 10$  is 9, the mean of the last three observations is  
(a)  $10\frac{1}{3}$             (b)  $10\frac{2}{3}$             (c)  $11\frac{1}{3}$             (d)  $11\frac{2}{3}$
5. If  $\bar{x}$  represents the mean of  $n$  observations  $x_1, x_2, x_3, \dots, x_n$ , then the value of  $\sum_{i=1}^n (x_i - \bar{x})$  is  
(a) -1            (b) 0            (c) 1            (d)  $n - 1$ .
6. If each observation of the data is increased by 5 then their mean  
(a) remains the same            (b) becomes 5 times the original mean  
(c) is decreased by 5            (d) is increased by 5.
7. There are 50 numbers. Each number  $s$  subtracted from 53 and the mean of the number so obtained is found to be 3.5. The mean of the given number is  
(a) 46.5            (b) 49.5            (c) 53.5            (d) 56.5.
8. The mean of 25 observations is 36. Out of these observations if the mean of first 13 observations is 32 and that of the last 13 observations is 40, the 13<sup>th</sup> observation is  
(a) 23            (b) 36            (c) 38            (d) 40.
9. The median of the data 78, 56, 22, 34, 45, 54, 39, 68, 54, 84 is  
(a) 45            (b) 49.5            (c) 54            (d) 56.
10. For drawing a frequency polygon of a continuous frequency distribution, we plot the points whose ordinates are the frequency of the respective classes and abscissa re respectively  
(a) upper limits of the classes            (b) lower limits of the classes  
(c) class marks of the classes            (d) upper limits of preceding classes.



**MCO WORKSHEET-IV**  
**CLASS IX: CHAPTER - 14**  
**STATISTICS**

1. The range of the data 14, 27, 29, 61, 45, 15, 9, 18 is  
A. 61                      B. 52                      C. 47                      D. 53
2. The class mark of the class 120-150 is  
A. 120                      B. 130                      C. 135                      D. 150
3. The class mark of a class is 10 and its class width is 6. The lower limit of the class is  
A. 5                      B. 7                      C. 8                      D. 10
4. In a frequency distribution, the class-width is 4 and the lower limit of first class is 10. If there are six classes, the upper limit of last class is  
A. 22                      B. 26                      C. 30                      D. 34
5. The class marks of a distribution are 15, 20, 25, ....., 45. The class corresponding to 45 is  
A. 12.5 – 17.5      B. 22.5 – 27.5      C. 42.5 – 47.5      D. None of these
6. The number of students in which two classes are equal.

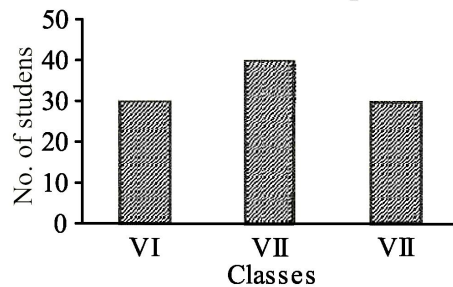

- A. VI and VIII      B. VI and VII      C. VII and VIII      D. None
7. The mean of first five prime numbers is  
A. 5.0                      B. 4.5                      C. 5.6                      D. 6.5
  8. The mean of first ten multiples of 7 is  
A. 35.0                      B. 36.5                      C. 38.5                      D. 39.2
  9. The mean of  $x + 3$ ,  $x - 2$ ,  $x + 5$ ,  $x + 7$  and  $x + 72$  is  
A.  $x + 5$                       B.  $x + 2$                       C.  $x + 3$                       D.  $x + 7$
  10. If the mean of  $n$  observations  $x_1, x_2, x_3, \dots, x_n$  is  $\bar{x}$  then  $\sum_{i=1}^n x_i - \bar{x}$  is  
A. 1                      B. -1                      C. zero                      D. can not be found
  11. The mean of 10 observation is 42. If each observation in the data is decreased by 12, the new mean of the data is  
A. 12                      B. 15                      C. 30                      D. 54

12. The the mean of 10 numbers is 15 and that of another 20 number is 24 then the mean of all 30 observations is
- A. 20                      B. 15                      C. 21                      D. 24
13. The median of 10, 12, 14, 16, 18, 20 is
- A. 12                      B. 14                      C. 15                      D. 16
14. If the median of 12, 13, 16,  $x + 2$ ,  $x + 4$ , 28, 30, 32 is 23, when  $x + 2$ ,  $x + 4$  lie between 16 and 30, then the value of  $x$  is
- A. 18                      B. 19                      C. 20                      D. 22
15. If the mode of 12, 16, 19, 16,  $x$ , 12, 16, 19, 12 is 16, then the value of  $x$  is
- A. 12                      B. 16                      C. 19                      D. 18
16. The mean of the following data is
- |       |   |    |    |    |    |
|-------|---|----|----|----|----|
| $x_i$ | 5 | 10 | 15 | 20 | 25 |
| $f_i$ | 3 | 5  | 8  | 3  | 1  |
- A. 12                      B. 13                      C. 13.5                      D. 13.6
- .....

**PRACTICE QUESTIONS**  
**CLASS IX: CHAPTER - 14**  
**STATISTICS**

1. Find the true class limits of the first two classes of the distribution 1–9, 10–19, 20–29, .....
2. The following are the marks obtained by 20 students in a class-test :  
40, 22, 36, 27, 30, 12, 15, 20, 25, 31, 34, 36, 39, 41, 43, 48, 46, 36, 37, 40  
Arrange the above data in frequency distribution with equal classes, one of them being (0–10), 10 not included.
3. The electricity bills of twenty house holds in a locality are as follows :  
370, 410, 520, 270, 810, 715, 1080, 712, 802, 775, 310, 375, 412, 420, 370, 218, 240, 250, 610, 570. Construct a frequency distribution table with class size 100.
4. The enrolment in classes VI to X of a school is given below :

Class :	VI	VII	VIII	IX	X
Enrolment :	70	65	60	45	35

Draw a bar chart to depict the data.
5. Draw a histogram and a frequency polygon for the following data :

Marks	10-20	20-30	30-40	40-50	50-60
No. of students	8	12	15	9	6
6. Draw a histogram for the following data :

Classes	10-15	15-20	20-30	30-50	50-80
Frequency	6	10	10	8	18
7. Find the mean of the following data :  
153, 140, 148, 150, 154, 142, 146, 147
8. The mean of the following data is 37. Find  $x$   
28, 35, 25, 32,  $x$ , 40, 45, 50
9. If the mean of  $n$  observation  $2x_1, 2x_2, \dots, 2x_n$  is  $2\bar{x}$ , show that  $\sum_{i=1}^n (x_i - 2\bar{x}) = 0$
10. The mean of 20 observations is 25. If each observation is multiplied by 2, then find the mean of new observations.
11. The means of two groups of 15 and 20 observations are 20 and 25 respectively. Find the mean of all the 35 observations.
12. If the mode of the following data is 14, find the value of  $x$   
10, 12, 14, 15, 16, 14, 15, 14, 15,  $x$ , 16, 14, 16
13. The median of the observations, arranged in increasing order is 26. Find the value of  $x$ .  
10, 17, 22,  $x + 2$ ,  $x + 4$ , 30, 36, 40
14. Find the mode of 14, 25, 14, 28, 18, 17, 18, 14, 23, 22, 14, 18.

15. Find the mean salary of 60 workers of a factory from the following table:

Salary (Rs)	Number of workers
3000	16
4000	12
5000	10
6000	8
7000	6
8000	4
9000	3
10000	1
<b>Total</b>	<b>60</b>

16. 100 surnames were randomly picked up from a local telephone directory and frequency distributions of the number of letters in the English alphabet in the surnames was found as follows:

Number of letters	Number of surnames
1 – 4	6
4 – 6	30
6 – 8	44
8 – 12	16
12 – 20	4

- (i) Draw a histogram to depict the given information.  
(ii) Write the class interval in which the maximum number of surnames lie.

17. In a mathematics test given to 15 students, the following marks (out of 100) are recorded:  
41, 39, 48, 52, 46, 62, 54, 40, 96, 52, 98, 40, 42, 52, 60

Find the mean, median and mode of this data.

18. A family with a monthly income of Rs 20,000 had planned the following expenditures per month under various heads: Draw a bar graph for the given below data.

Heads	Expenditure (in thousand rupees)
Grocery	4
Rent	5
Education of children	5
Medicine	2
Fuel	2
Entertainment	1
Miscellaneous	1

19. The value of  $\pi$  upto 50 decimal places is given below:

3.14159265358979323846264338327950288419716939937510 (i) Make a frequency distribution of the digits from 0 to 9 after the decimal point. (ii) What are the most and the least frequently occurring digits?

20. The following observations have been arranged in ascending order as 29, 32, 48, 50,  $x$ ,  $x + 2$ , 72, 78, 84, 95. If the median of the data is 63, find the value of  $x$ .

21. Consider the marks, out of 100, obtained by 51 students of a class in a test, given in below table. Draw a frequency polygon corresponding to this frequency distribution table.

Marks	Number of students
0 - 10	5
10 - 20	10
20 - 30	4
30 - 40	6
40 - 50	7
50 - 60	3
60 - 70	2
70 - 80	2
80 - 90	3
90 - 100	9
<b>Total</b>	<b>51</b>

22. In a city, the weekly observations made in a study on the cost of living index are given below in the following table: Draw a frequency polygon for the data above (without constructing a histogram).

Cost of living index	Number of weeks
140 - 150	5
150 - 160	10
160 - 170	20
170 - 180	9
180 - 190	6
190 - 200	2
<b>Total</b>	<b>52</b>

23. The following table gives the life times of 400 neon lamps: (i) Represent the given information with the help of a histogram. (ii) How many lamps have a life time of more than 700 hours?

Life time (in hours)	Number of lamps
300 – 400	14
400 – 500	56
500 – 600	60
600 – 700	86
700 – 800	74
800 – 900	62
900 – 1000	48

24. The mean of 13 observations is 14. If the mean of the first 7 observations is 12 and that of last 7 observation is 16, find the 7<sup>th</sup> observation.
25. The average monthly salary of 15 workers in a factory is Rs. 285. If the salary of the manager is included, the average becomes Rs. 355. What is the manager's salary?

26. For what value of  $x$ , is the mode of the following data is 17?  
15, 16, 17, 14, 17 16, 13,  $x$ , 17, 16, 15, 15

27. The runs scored by two teams A and B on the first 60 balls in a cricket match are given below:  
Represent the data of both the teams on the same graph by frequency polygons.

Number of balls	Team A	Team B
1 - 6	2	5
7 - 12	1	6
13 - 18	8	2
19 - 24	9	10
25 - 30	4	5
31 - 36	5	6
37 - 42	6	3
43 - 48	10	4
49 - 54	6	8
55 - 60	2	10

28. A random survey of the number of children of various age groups playing in a park was found as follows: Draw a histogram to represent the data above.

Age(in years)	Number of children
1 - 2	5
2 - 3	3
3 - 5	6
5 - 7	12
7 - 10	9
10 - 15	10
15 - 17	4

29. Calculate mean (by using assume mean method), median and mode.

<b>Income</b>	50	150	250	350	450	550	650	750
<b>No. of persons</b>	4	8	9	10	7	5	4	3

30. The mean of the following distribution is 107. Find the value of  $f_1$  and  $f_2$ .

<b>x</b>	15	45	75	105	135	165	195	<b>Total</b>
<b>f</b>	2	3	$f_1$	10	3	$f_2$	2	30

31. Find the median of the distribution obtained in question no.2.

32. Find the median of first sixteen odd numbers.

33. Find the median of first ten prime numbers.

34. A school has two sections. The mean mark of one section of size 40 is 60 and mean mark of other section of size 60 is 80. Find the combined mean of all the students of the school.

35. The median of the following observations arranged in ascending order 8, 9, 12, 18,  $(x + 2)$ ,  $(x + 4)$ , 30, 31, 34, 39 is 24. Find  $x$ .

36. The mean weight of 180 students in a school is 50kg. The mean weight of boys is 60kg while that of the girls is 45kg. Find the number of the boys and girls in the school.

37. Draw histogram and frequency polygon for the following distribution:

<b>C. I.</b>	0 – 50	50 – 100	100 – 150	150 – 200	200 – 250	250 – 300
<b>F</b>	4	8	16	13	6	3

38. Calculate mean by step deviation method:

Marks	5.5	15.5	25.5	35.5	45.5	55.5
No. of Students	3	16	26	31	16	8

39. The mean of the following distribution is 15. Find the value of a.

C. I.	5	10	15	20	25
Freq	6	a	6	10	5

40. Calculate mean by step deviation method:

Marks	15	25	35	45	55
No. of Students	20	24	40	36	20

41. The mean of the following distribution is 50. Find the value of p.

C. I.	10	30	50	70	90
Freq	17	p	32	24	19

42. Find the missing frequencies from the frequency distribution if the mean is 472 for 100 workers

Income	250	350	450	550	650	750	850
No. of workers	5	x	y	16	9	6	4

43. In a school 90 boys and 30 girls appeared in a public examination. The mean marks of boys was found to be 45% whereas the mean marks of girls was 70%. Determine the average marks % of the school.

44. The marks secured by 15 students are 70, 55, 95, 62, 82, 65, 60, 68, 75, 58, 64, 85, 80, 90, 51. Find the median marks.

45. Calculate mean (by using short cut method), median and mode.

Marks	25	35	45	55	65	75	85	95
No. of Students	5	12	6	20	18	10	16	3

46. The mean of the following distribution is 112.2 for the sum of observation 100. Find the value of x and y.

C. I.	60	80	100	120	140	160
Freq	18	X	13	27	Y	22

47. The median of the following observations arranged in ascending order 8, 9, 12, 18, (x + 2), (x + 4), 30, 31, 34, 39 is 24. Find x.

48. If the mean of  $2x + 3$ ,  $3x + 4$ ,  $x + 7$ ,  $x - 3$ ,  $4x - 7$  is 14. Find the value of x.

49. The mean of 8 numbers is 15. If each number is multiplied by 2, what will be the new mean?

50. Find the mean (by using assume mean method), median and mode of the following distribution:

x	15	25	35	45	55	65
f	90	50	60	80	50	30

51. Find the mean (by using step deviation method), median and mode of the given data:

x	6	10	14	18	22	26	30
f	2	4	7	12	8	4	3

52. Draw histogram and frequency polygon for the following data:

Marks	10 – 20	20 – 30	30 – 40	40 – 50	50 – 60
No. of students	10	12	13	11	9

53. The mean of 25 observations is 36. If the mean of the first 13 observations is 32 and that of the last 13 observations is 39, find the 13<sup>th</sup> observation.

54. Find mean (by using assume mean method), median and mode of the following table:

Salaries (in Rs.)	1500	2000	2500	3000	3500	4000	4500	5000
No. of workers	16	12	10	8	6	4	3	1

55. Find the mean (by using step deviation method), median and mode of the following distribution:

x	24.5	34.5	44.5	54.5	64.5	74.5	84.5	94.5
f	5	12	15	20	18	10	6	4

56. For the following data, draw a histogram and a frequency polygon.

Marks	20-30	30-40	40-50	50-60	60-70	70-80	80-90	90-100
No. of students	5	12	6	20	18	10	16	3

57. Given below are the ages of 25 students of class IX in a school.

Prepare a discrete frequency distribution table.

15 16 16 17 17 16 15 15 16 16 17 15 16  
16 14 16 15 14 15 16 16 15 14 14 15

58. Find the median of the following data: 33, 31, 48, 45, 41, 92, 78, 51, and 61. If 92 is replaced by 29, what will be the new median?

59. Following are the marks of a group of students in a test of reading ability test:

Marks:	50 – 52	47 – 49	44 – 46	41 – 43	38 – 40	35 – 37	32 – 34	Total
No. of students	4	10	15	18	20	12	13	92

Construct a histogram and frequency polygon for the above data.

60. For the following data, draw a histogram and a frequency polygon

x	0 – 10	10 – 20	20 – 30	30 – 50	50 – 60	60 – 80	80 – 90	90 – 100
f	5	12	15	20	18	10	6	4



**MCQ WORKSHEET-I**  
**CLASS IX: CHAPTER - 15**  
**PROBABILITY**

1. There are 6 marbles in a box with number 1 to 6 marked on each of them . What is the probability of drawing a marble with number 2 ?  
(a)  $\frac{1}{6}$                       (b)  $\frac{1}{5}$                       (c)  $\frac{1}{3}$                       (d) 1
2. A coin is flipped to decide which team starts the game . What is the probability of your team will start ?  
(a)  $\frac{1}{4}$                       (b)  $\frac{1}{2}$                       (c) 1                      (d) 0
3. A die is thrown once . What will be the probability of getting a prime number ?  
(a)  $\frac{1}{6}$                       (b)  $\frac{1}{2}$                       (c) 1                      (d) 0

Cards marked with numbers 1 to 25 are placed in the box and mixed thoroughly. One card is drawn at random from the box. Answer the following questions (Q4-Q13)

4. What is the probability of getting a number 5?  
(a) 1                      (b) 0                      (c)  $\frac{1}{25}$                       (d)  $\frac{1}{5}$
5. What is the probability of getting a number less than 11?  
(a) 1                      (b) 0                      (c)  $\frac{1}{5}$                       (d)  $\frac{2}{5}$
6. What is the probability of getting a number greater than 25?  
(a) 1                      (b) 0                      (c)  $\frac{1}{5}$                       (d)  $\frac{2}{5}$
7. What is the probability of getting a multiple of 5?  
(a) 1                      (b) 0                      (c)  $\frac{1}{25}$                       (d)  $\frac{1}{5}$
8. What is the probability of getting an even number?  
(a) 1                      (b) 0                      (c)  $\frac{12}{25}$                       (d)  $\frac{13}{25}$
9. What is the probability of getting an odd number?  
(a) 1                      (b) 0                      (c)  $\frac{12}{25}$                       (d)  $\frac{13}{25}$
10. What is the probability of getting a prime number?  
(a)  $\frac{8}{25}$                       (b)  $\frac{9}{25}$                       (c)  $\frac{12}{25}$                       (d)  $\frac{13}{25}$

11. What is the probability of getting a number divisible by 3?

- (a)  $\frac{8}{25}$                       (b)  $\frac{9}{25}$                       (c)  $\frac{12}{25}$                       (d)  $\frac{13}{25}$

12. What is the probability of getting a number divisible by 4?

- (a)  $\frac{8}{25}$                       (b)  $\frac{9}{25}$                       (c)  $\frac{6}{25}$                       (d)  $\frac{3}{25}$

13. What is the probability of getting a number divisible by 7?

- (a)  $\frac{8}{25}$                       (b)  $\frac{9}{25}$                       (c)  $\frac{6}{25}$                       (d)  $\frac{3}{25}$

14. A bag has 4 red balls and 2 yellow balls. A ball is drawn from the bag without looking into the bag. What is probability of getting a red ball?

- (a)  $\frac{1}{6}$                       (b)  $\frac{2}{3}$                       (c)  $\frac{1}{3}$                       (d) 1

15. A bag has 4 red balls and 2 yellow balls. A ball is drawn from the bag without looking into the bag. What is probability of getting a yellow ball?

- (a)  $\frac{1}{6}$                       (b)  $\frac{2}{3}$                       (c)  $\frac{1}{3}$                       (d) 1



**MCQ WORKSHEET-II**  
**CLASS IX: CHAPTER - 15**  
**PROBABILITY**

A box contains 3 blue, 2 white, and 5 red marbles. If a marble is drawn at *random* from the box, then answer the questions from 1 to 5.

1. What is the probability that the marble will be white?

- (a)  $\frac{1}{6}$                       (b)  $\frac{1}{5}$                       (c)  $\frac{1}{3}$                       (d) 1

2. What is the probability that the marble will be red?

- (a)  $\frac{1}{6}$                       (b)  $\frac{1}{2}$                       (c) 1                      (d) 0

3. What is the probability that the marble will be blue?

- (a)  $\frac{3}{10}$                       (b)  $\frac{1}{2}$                       (c) 1                      (d) 0

4. What is the probability that the marble will be any one colour?

- (a)  $\frac{1}{6}$                       (b)  $\frac{1}{2}$                       (c) 1                      (d) 0

5. What is the probability that the marble will be red or blue?

- (a) 1                      (b)  $\frac{4}{5}$                       (c)  $\frac{1}{5}$                       (d)  $\frac{2}{5}$

A die is thrown once, then answer the questions from 6 to 10.

6. Find the probability of getting a prime number

- (a)  $\frac{1}{6}$                       (b)  $\frac{1}{2}$                       (c) 1                      (d) 0

7. Find the probability of getting a number lying between 2 and 6

- (a)  $\frac{1}{6}$                       (b)  $\frac{1}{2}$                       (c) 1                      (d) 0

8. Find the probability of getting an odd number.

- (a)  $\frac{1}{6}$                       (b)  $\frac{1}{2}$                       (c) 1                      (d) 0

9. Find the probability of getting an even number.

- (a)  $\frac{1}{6}$                       (b)  $\frac{1}{2}$                       (c) 1                      (d) 0

10. Find the probability of getting a number greater than 4.

- (a)  $\frac{1}{6}$                       (b)  $\frac{2}{3}$                       (c)  $\frac{1}{3}$                       (d) 1

**MCQ WORKSHEET-III**  
**CLASS IX: CHAPTER - 15**  
**PROBABILITY**

A box contains 5 red marbles, 6 white marbles and 4 green marbles. If a marble is drawn at random from the box, then answer the questions from 1 to 6.

1. What is the probability that the marble will be white?  
(a)  $\frac{1}{6}$                       (b)  $\frac{2}{3}$                       (c)  $\frac{1}{3}$                       (d) 1
2. What is the probability that the marble will be red?  
(a)  $\frac{1}{6}$                       (b)  $\frac{2}{3}$                       (c)  $\frac{1}{3}$                       (d) 1
3. What is the probability that the marble will be green?  
(a) 0.3                      (b)  $\frac{1}{2}$                       (c) 1                      (d) none of these
4. What is the probability that the marble will be any one colour?  
(a)  $\frac{1}{6}$                       (b)  $\frac{1}{2}$                       (c) 1                      (d) 0
5. What is the probability that the marble will be red or green?  
(a)  $\frac{2}{5}$                       (b)  $\frac{3}{25}$                       (c)  $\frac{1}{5}$                       (d) none of these
6. What is the probability that the marble will be blue?  
(a)  $\frac{1}{6}$                       (b)  $\frac{1}{2}$                       (c) 1                      (d) 0

Cards marked with numbers 1 to 50 are placed in the box and mixed thoroughly. One card is drawn at random from the box. Answer the following questions from 7 to 15.

7. What is the probability of getting a number 5?  
(a) 1                      (b) 0                      (c)  $\frac{1}{25}$                       (d)  $\frac{1}{5}$
8. What is the probability of getting a number less than 11?  
(a) 1                      (b) 0                      (c)  $\frac{1}{5}$                       (d)  $\frac{2}{5}$
9. What is the probability of getting a number greater than 50?  
(a) 1                      (b) 0                      (c)  $\frac{1}{5}$                       (d)  $\frac{2}{5}$
10. What is the probability of getting a multiple of 5?  
(a) 1                      (b) 0                      (c)  $\frac{1}{25}$                       (d)  $\frac{1}{5}$

11. What is the probability of getting an even number?

- (a) 1                      (b)  $\frac{1}{2}$                       (c)  $\frac{12}{25}$                       (d)  $\frac{13}{25}$

12. What is the probability of getting an odd number?

- (a) 1                      (b)  $\frac{1}{2}$                       (c)  $\frac{12}{25}$                       (d)  $\frac{13}{25}$

13. What is the probability of getting a prime number?

- (a) 1                      (b)  $\frac{1}{2}$                       (c)  $\frac{4}{10}$                       (d)  $\frac{3}{10}$

14. What is the probability of getting a number divisible by 3?

- (a)  $\frac{8}{25}$                       (b)  $\frac{9}{25}$                       (c)  $\frac{12}{25}$                       (d)  $\frac{13}{25}$

15. What is the probability of getting a number divisible by 4?

- (a)  $\frac{8}{25}$                       (b)  $\frac{9}{25}$                       (c)  $\frac{6}{25}$                       (d)  $\frac{3}{25}$

16. What is the probability of getting a number divisible by 7?

- (a)  $\frac{8}{25}$                       (b)  $\frac{9}{25}$                       (c)  $\frac{6}{25}$                       (d)  $\frac{3}{25}$



MCQ WORKSHEET-IV  
CLASS IX: CHAPTER - 15  
PROBABILITY

1. A coin is tossed 1000 times and 560 times a "head" occurs. The empirical probability of occurrence of a Head in this case is
- A. 0.5                      B. 0.56                      C. 0.44                      D. 0.056

2. Two coins are tossed 200 times and the following out comes are recorded

HH	HT/TH	TT
56	110	34

What is the empirical probability of occurrence of at least one Head in the above case

- A. 0.33                      B. 0.34                      C. 0.66                      D. 0.83

A die is thrown 200 times and the following outcomes are noted, with their frequencies:

Outcome	1	2	3	4	5	6
Frequency	56	22	30	42	32	18

3. What is the empirical probability of getting a 1 in the above case.
- A. 0.28                      B. 0.22                      C. 0.15                      D. 0.21

4. What is the empirical probability of getting a number less than 4 ?
- A. 0.50                      B. 0.54                      C. 0.46                      D. 0.52

5. What is the empirical probability. of getting a number greater than 4.
- A. 0.32                      B. 0.25                      C. 0.18                      D. 0.30

6. On a particular day, the number of vehicles passing a crossing is given below :

Vehicle	Two wheeler	Three wheeler	Four wheeler
Frequency	52	71	77

What is the probability of a two wheeler passing the crossing on that day ?

- A. 0.26                      B. 0.71                      C. 0.385                      D. 0.615

7. The following table shows the blood-group of 100 students

Blood group	A	B	O	AB	B <sup>+</sup>
Number of Students	12	23	35	20	10

One student is taken at random. What is probability that his blood group is B<sup>+</sup>

- A. 0.12                      B. 0.35                      C. 0.20                      D. 0.10

8. In a bag, there are 100 bulbs out of which 30 are bad ones. A bulb is taken out of the bag at random. The probability of the selected bulb to be good is

- A. 0.50                      B. 0.70                      C. 0.30                      D. None of these

9. On a page of telephone directory having 250 telephone numbers, the Frequency of the unit digits of those number are given below :

0	1	2	3	4	5	6	7	8	9
18	22	32	28	40	30	30	22	18	10

A telephone number is selected from the page at random. What is the probability that its unit digit is

(a)2

- A. 0.16                      B. 0.128                      C. 0.064                      D. 0.04

(b) More than 6

- A. 0.20                      B. 0.25                      C. 0.32                      D. 0.16

(c) less than 2

- A. 0.16                      B. 0.18                      C. 0.22                      D. 0.32

10. 10 defective pens are accidentally mixed with 90 good ones. It is not possible to just look at a pen and tell whether or not it is defective. One pen is taken out at random from this lot. Determine the probability that the pen taken out is a good one.

- A. 0.10                      B. 0.20                      C. 0.90                      D. 1.0



**PRACTICE QUESTIONS**  
**CLASS IX: CHAPTER - 15**  
**PROBABILITY**

- Write all possible outcomes when
  - one coin is tossed.
  - two coins are tossed.
  - one die is rolled.
- Three coins are tossed simultaneously 100 times. The following outcomes are recorded.

<b>Outcome</b>	3 tails	2 tails	1 tail	No tail
<b>Frequency</b>	23	28	23	26

Find the probability of coming up more than one tail.

- A die is thrown 300 times with the frequencies for the outcomes 1, 2, 3, 4, 5 and 6 as given in the following table :

<b>Outcome</b>	1	2	3	4	5	6
<b>Frequency</b>	42	60	55	53	60	30

Find the probability of getting (i) an even number (ii) a prime number and (iii) a number more than 4.

- A box contains 3 blue, 2 white, and 4 red marbles. If a marble is drawn at *random* from the box, what is the probability that it will be (i) white? (ii) blue? (iii) red?
- A coin is tossed 1000 times with the following frequencies: Head : 455, Tail : 545 Compute the probability for getting head.
- Two coins are tossed simultaneously 500 times, and we get Two heads : 105 times, One head : 275 times and No head : 120 times. Find the probability of occurrence of two heads.
- A die is thrown 1000 times with the frequencies for the outcomes 1, 2, 3, 4, 5 and 6 as given in the following table :

<b>Outcome</b>	1	2	3	4	5	6
<b>Frequency</b>	179	150	157	149	175	190

Find the probability of getting (i) an odd number (ii) a prime number and (iii) a number greater than 4.

- 12 defective pens are accidentally mixed with 132 good ones. It is not possible to just look at a pen and tell whether or not it is defective. One pen is taken out at random from this lot. Determine the probability that the pen taken out is a good one.
- On one page of a telephone directory, there were 200 telephone numbers. The frequency distribution of their unit place digit (for example, in the number 25828573, the unit place digit is 3) is given in Table 15.7 :

<b>Digit</b>	0	1	2	3	4	5	6	7	8	9
<b>Frequency</b>	22	26	22	22	20	10	14	28	16	20

Without looking at the page, the pencil is placed on one of these numbers, i.e., the number is chosen at *random*. What is the probability that the digit in its unit place is (i) an odd number (ii) a prime number and (iii) a number greater than 4.?



10. A box contains 90 discs which are numbered from 1 to 90. If one disc is drawn at random from the box, find the probability that it bears (i) a two-digit number (ii) a perfect square number (iii) a number divisible by 5.
11. A lot consists of 144 ball pens of which 20 are defective and the others are good. Nuri will buy a pen if it is good, but will not buy if it is defective. The shopkeeper draws one pen at random and gives it to her. What is the probability that (i) She will buy it ? (ii) She will not buy it ?
12. A bag contains 3 red balls and 5 black balls. A ball is drawn at random from the bag. What is the probability that the ball drawn is (i) red ? (ii) not red?
13. A box contains 5 red marbles, 8 white marbles and 4 green marbles. One marble is taken out of the box at random. What is the probability that the marble taken out will be (i) red ? (ii) white ? (iii) not green?
14. A die is thrown once. Find the probability of getting (i) a prime number; (ii) a number lying between 2 and 6; (iii) an odd number.
15. A bag contains 5 red, 8 green and 7 white balls. One ball is drawn at random from the bag, find the probability of getting (i) a white ball or a green ball and (ii) neither green ball nor red ball.
16. Harpreet tosses two different coins simultaneously. What is the probability that she gets *at least* one head?
17. A company selected 4000 households at random and surveyed them to find out a relationship between income level and the number of television sets in a home. The information so obtained is listed in the following table:

Monthly income (in Rs.)	Number of Televisions/household			
	0	1	2	Above 2
< 10000	20	80	10	0
10000 – 14999	10	240	60	0
15000 – 19999	0	380	120	30
20000 – 24999	0	520	370	80
25000 and above	0	1100	760	220

Find the probability:

- (i) of a household earning Rs 10000 – Rs 14999 per year and having exactly one television.  
(ii) of a household earning Rs 25000 and more per year and owning 2 televisions.  
(iii) of a household not having any television.
18. Cards are marked with numbers 4, 5, 6, .....50 are placed in the box and mixed thoroughly. One card is drawn at random from the box. What is the probability of getting (i) an even prime number (ii) a number divisible by 5 and (iii) multiple of 7?
19. The record of a weather station shows that out of the past 250 consecutive days, its weather forecasts were correct 175 times. (i) What is the probability that on a given day it was correct? (ii) What is the probability that it was not correct on a given day?
20. Two dice are thrown simultaneously 500 times. Each time the sum of two numbers appearing on their tops is noted and recorded as given in the following table:

<b>Sum</b>	2	3	4	5	6	7	8	9	10	11	12
<b>Frequency</b>	14	30	42	55	72	75	70	53	46	28	15

If the dice are thrown once more, what is the probability of getting a sum (i) 3? (ii) more than 10? (iii) less than or equal to 5? (iv) between 8 and 12?

21. Bulbs are packed in cartons each containing 40 bulbs. Seven hundred cartons were examined for defective bulbs and the results are given in the following table:

<b>Number of defective bulbs</b>	0	1	2	3	4	5	6	More than 6
<b>Frequency</b>	400	180	48	41	18	8	3	2

One carton was selected at random. What is the probability that it has

- (i) no defective bulb?
- (ii) defective bulbs from 2 to 6?
- (iii) defective bulbs less than 4?

22. Over the past 200 working days, the number of defective parts produced by a machine is given in the following table:

<b>Number of defective parts</b>	0	1	2	3	4	5	6	7	8	9	10	11	12	13
<b>Days</b>	50	32	22	18	12	12	10	10	10	8	6	6	2	2

Determine the probability that tomorrow's output will have

- (i) no defective part
- (ii) atleast one defective part
- (iii) not more than 5 defective parts
- (iv) more than 13 defective parts

23. A recent survey found that the ages of workers in a factory is distributed as follows:

<b>Age(in years)</b>	20 – 29	30 – 39	40 – 49	50 – 59	60 and above
<b>Number of workers</b>	38	27	86	46	3

If a person is selected at random, find the probability that the person is:

- (i) 40 years or more
- (ii) under 40 years

24. Three coins are tossed simultaneously 200 times with the following frequencies of different outcomes:

<b>Outcomes</b>	3 heads	2 heads	1 head	No head
<b>Frequency</b>	23	72	77	28

If the three coins are simultaneously tossed again, compute the probability of getting

- (i) 2 heads.
- (ii) at least 2 heads
- (iii) at most 2 heads



## SET – 01

### **BLUE PRINT : SA-II (IX) : MATHEMATICS**

<b>Unit/Topic</b>	<b>MCQ (1 mark)</b>	<b>Short answer (2 marks)</b>	<b>Short answer (3 marks)</b>	<b>Long answer (4 marks)</b>	<b>Total</b>
<b>Algebra</b> Linear Equations in two variables	--	--	6(2)	4(1)	<b>10(3)</b>
<b>Geometry</b> Quadrilaterals, Area, Circles & Construction	1(1)	6(3)	3(1)	28(7)	<b>38(12)</b>
<b>Mensuration</b> Surface Areas and Volumes	2(2)	--	12(4)	8(2)	<b>22(8)</b>
<b>Statistics</b>	--	2(1)	6(2)	4(1)	<b>12(4)</b>
<b>Probability</b>	1(1)	4(2)	3(1)	--	<b>8(4)</b>
<b>Total</b>	<b>4(4)</b>	<b>12(6)</b>	<b>30(10)</b>	<b>44(11)</b>	<b>90(31)</b>

*The test of OTBA for SA-II will be from Unit-II Linear Equation in Two variables*

# SAMPLE PAPER – I

**Class – IX**  
**Subject: Mathematics**

**Max. Marks: 90**  
**Time Allowed: 3 hrs**

---

**General Instruction:**

- (i) All questions are compulsory.
  - (ii) The question paper consists of 34 questions divided into four sections A, B, C and D.
  - (iii) Section A contains 8 multiple-choice questions of 1 mark each. Section B contains 6 questions of 2 marks each. Section C contains 10 questions of 3 marks each. Section D contains 10 questions of 4 marks each.
  - (iv) Use of calculator is not permitted.
- 

## SECTION – A

**Question numbers 1 to 8 carry 1mark each. For each question, four alternative choices have been provided of which only one is correct. You have to select the correct choice.**

1. If the length of a chord of a circle at a distance of 5 cm from the centre of the circle is 24 cm, find the radius of the circle.  
(a) 13 cm      (b) 14 cm      (c) 16 cm      (d) 15 cm
2. The curved surface area of a cylinder of height 14 cm is  $88 \text{ cm}^2$ . The diameter of its circular base is (a) 5cm      (b) 4cm      (c) 3cm      (d) 2cm
3. A bag has 4 red balls and 2 yellow balls. A ball is drawn from the bag without looking into the bag. What is probability of getting a yellow ball?  
(a)  $\frac{1}{6}$       (b)  $\frac{2}{3}$       (c)  $\frac{1}{3}$       (d) 1
4. Base radius of two cylinder are in the ratio 2 : 3 and their heights are in the ratio 5 : 3. The ratio of their volumes is  
(a) 27 : 20      (b) 25 : 24      (c) 20 : 27      (d) 15 : 20

## SECTION – B

**Question numbers 9 to 14 carry 2 marks each.**

5. In the below fig. O is any point on the diagonal BD of the parallelogram ABCD. Prove that  $\text{ar}(\triangle OAB) = \text{ar}(\triangle OBC)$ .

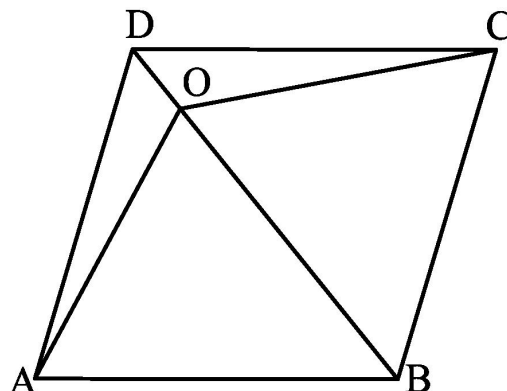

6. The record of a weather station shows that out of the past 250 consecutive days, its weather forecasts were correct 175 times. (i) What is the probability that on a given day it was correct? (ii) What is the probability that it was not correct on a given day?
7. The following observations have been arranged in ascending order as 29, 32, 48, 50,  $x$ ,  $x + 2$ , 72, 78, 84, 95. If the median of the data is 63, find the value of  $x$ .
8. Angles of a quadrilateral are in the ratio 3 : 4 : 4 : 7. Find all the angles of the quadrilateral.
9. Cards are marked with numbers 4, 5, 6, .....50 are placed in the box and mixed thoroughly. One card is drawn at random from the box. What is the probability of getting (i) an even prime number (ii) a number divisible by 5?
10. In the below figure, A, B, C and D are four points on a circle. AC and BD intersect at a point E such that  $\angle BEC = 130^\circ$  and  $\angle ECD = 20^\circ$ . Find  $\angle BAC$ .

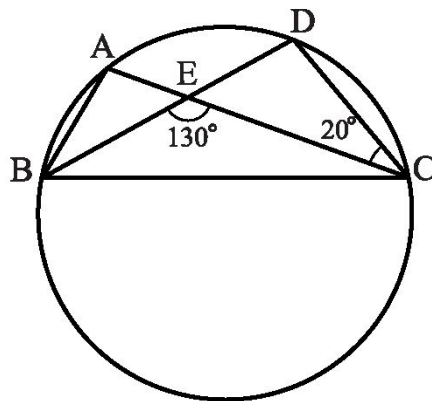

### SECTION – C

**Question numbers 15 to 24 carry 3 marks each.**

11. A box contains 5 red marbles, 8 white marbles and 4 green marbles. One marble is taken out of the box at random. What is the probability that the marble taken out will be (i) red ? (ii) white ? (iii) not green?
12. A joker's cap is in the form of a right circular cone of base radius 7 cm and height 24 cm. Find the area of the sheet required to make 10 such caps.
13. The value of  $\pi$  upto 50 decimal places is given below:  
3.14159265358979323846264338327950288419716939937510  
(i) Make a frequency distribution of the digits from 0 to 9 after the decimal point. (ii) What are the most and the least frequently occurring digits?
14. OTBA Question from Linear Equation in two variables
15. OTBA Question from Linear Equation in two variables
16. In a quadrilateral ABCD, AO and BO are the bisectors of  $\angle A$  and  $\angle B$  respectively. Prove that  
$$\angle AOB = \frac{1}{2}(\angle C + \angle D)$$
17. A right triangle ABC with sides 5 cm, 12 cm and 13 cm is revolved about the side 12 cm. Find the volume of the solid so obtained.

18. For the following data, draw a histogram and a frequency polygon

<b>x</b>	0 – 20	20 – 30	30 – 50	50 – 60	60 – 80	80 – 100
<b>f</b>	12	15	20	18	10	14

19. A river, 3 m deep and 40m wide, is flowing at the rate of 2km/hr. How much water will fall into the sea in a minute?

20. A conical tent is 10 m high and the radius of its base is 24 m. Find (i) slant height of the tent. (ii) cost of the canvas required to make the tent, if the cost of 1 m<sup>2</sup> canvas is Rs 70.

### SECTION – D

**Question numbers 25 to 34 carry 4 marks each.**

21. Construct a triangle XYZ in which  $\angle Y = 30^\circ$ ,  $\angle Z = 90^\circ$  and  $XY + YZ + ZX = 11$  cm.

22. Find the mean of the following data:

<b>Income</b>	50	150	250	350	450	550	650	750
<b>No. of persons</b>	4	8	9	10	7	5	4	3

23. In the below figure, AB is a diameter of the circle, CD is a chord equal to the radius of the circle. AC and BD when extended intersect at a point E. Prove that  $\angle AEB = 60^\circ$ .

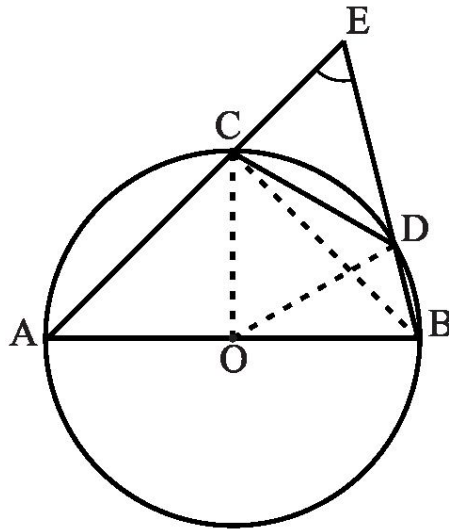

24. Prove that “The line segment joining the mid-points of two sides of a triangle is parallel to the third side and half of it”.

25. Prove that “The angle subtended by an arc at the centre is double the angle subtended by it at any point on the remaining part of the circle.”

26. Prove that “The sum of either pair of opposite angles of a cyclic quadrilateral is 180°.”

27. OTBA Question from Linear Equation in two variables

28. A school provides milk to the students daily in a cylindrical glasses of diameter 7 cm. If the glass is filled with milk upto an height of 12 cm, find how many litres of milk is needed to serve 1600 students. What are the benefits of taking milk daily?

29. 30 circular plates, each of radius 14 cm and thickness 3cm are placed one above the another to form a cylindrical solid. Find : (i) the total surface area (ii) volume of the cylinder so formed.

30. In the below figure, ABCDE is any pentagon. BP drawn parallel to AC meets DC produced at P and EQ drawn parallel to AD meets CD produced at Q. Prove that ar (ABCDE) = ar (APQ)

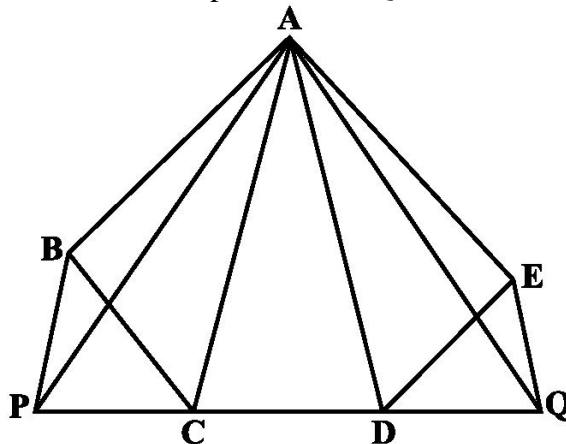

31. In fig. P is a point in the interior of a parallelogram ABCD. Show that ar (APD) + ar (PBC) = ar (APB) + ar (PCD)

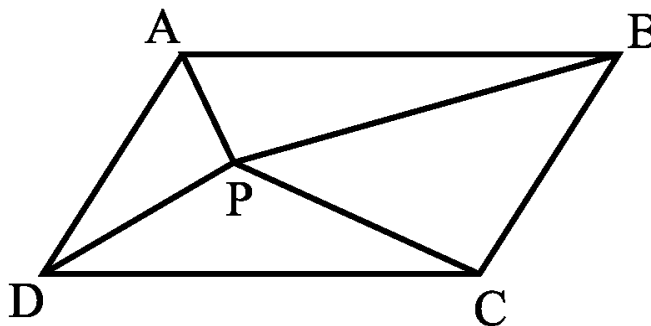

## SET – 02

### **BLUE PRINT : SA-II (IX) : MATHEMATICS**

<b>Unit/Topic</b>	<b>MCQ (1 mark)</b>	<b>Short answer (2 marks)</b>	<b>Short answer (3 marks)</b>	<b>Long answer (4 marks)</b>	<b>Total</b>
<b>Algebra</b> Linear Equations in two variables	--	--	6(2)	4(1)	<b>10(3)</b>
<b>Geometry</b> Quadrilaterals, Area, Circles & Construction	2(2)	6(3)	6(2)	24(6)	<b>38(13)</b>
<b>Mensuration</b> Surface Areas and Volumes	1(1)	--	9(3)	12(3)	<b>22(7)</b>
<b>Statistics</b>	1(1)	4(2)	3(1)	4(1)	<b>12(5)</b>
<b>Probability</b>	--	2(1)	6(2)	--	<b>8(2)</b>
<b>Total</b>	<b>4(4)</b>	<b>12(6)</b>	<b>30(10)</b>	<b>44(11)</b>	<b>90(31)</b>

*The test of OTBA for SA-II will be from Unit-II Linear Equation in Two variables*



# SAMPLE PAPER – II

**Class – IX**  
**Subject: Mathematics**

**Max. Marks: 90**  
**Time Allowed: 3 hrs**

---

**General Instruction:**

- (i) All questions are compulsory.
  - (ii) The question paper consists of 34 questions divided into four sections A, B, C and D.
  - (iii) Section A contains 8 multiple-choice questions of 1 mark each. Section B contains 6 questions of 2 marks each. Section C contains 10 questions of 3 marks each. Section D contains 10 questions of 4 marks each.
  - (iv) Use of calculator is not permitted.
- 

**SECTION-A**

**Question numbers 1 to 8 carry 1mark each. For each question, four alternative choices have been provided of which only one is correct. You have to select the correct choice.**

1. The median of a triangle divides it into two  
(A) triangles of equal area (B) equilateral triangles  
(C) right triangles (D) isosceles triangles
2. In Fig.1, AOB is a diameter of the circle and  $AC = BC$ , then  $\angle CAB$  is equal to  
(A)  $30^\circ$  (B)  $45^\circ$  (C)  $90^\circ$  (D)  $60^\circ$

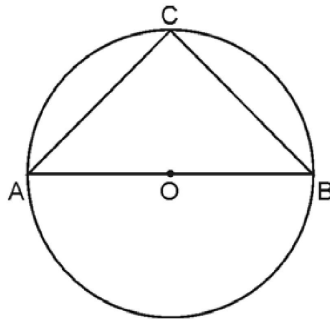

3. In a frequency distribution, the mid-value of a class is 20 and the width of the class is 8, then the lower limit of the class is  
(A) 12 (B) 24 (C) 28 (D) 16
4. If the volume of a sphere is numerically equal to its surface area, then radius of the sphere is  
(A) 1 unit (B) 3 units (C) 2 units (D) 6 units

**SECTION-B**

**Question numbers 9 to 14 carry 2 marks each.**

5. D and E are points on sides AB and AC respectively of  $\triangle ABC$  such that  $\text{ar}(\triangle DBC) = \text{ar}(\triangle EBC)$ . Prove that  $DE \parallel BC$ .
6. Find the mode of the following data:  
5, 7, 6, 5, 9, 8, 6, 7, 11, 10, 5, 7, 6, 8, 6, 9, 10.
7. In a cricket match, a batsman hits a boundary 4 times out of 30 balls, he plays. Find the probability that he did not hit a boundary.
8. Prove that equal chords of a circle subtend equal angles at the centre.

9. In the below figure,  $\angle DAB = 70^\circ$ ,  $\angle DBA = 35^\circ$ . Find the measure of  $\angle ACB$ .

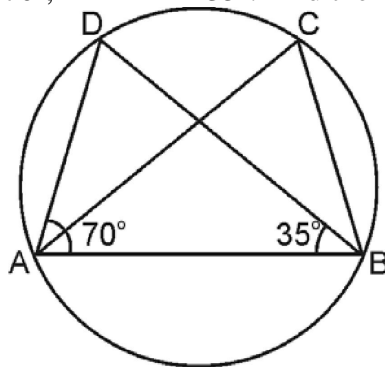

10. The mean of the following data is 37. Find x  
28, 35, 25, 32, x, 40, 45, 50

### SECTION-C

Question numbers 15 to 24 carry 3 marks each.

11. Prove that a diagonal of a parallelogram divides it into two congruent triangles.

12. OTBA Question from Linear Equation in two variables

13. A lead pencil consists of a cylinder of wood with a solid cylinder of graphite filled in the interior. The diameter of the pencil is 7mm and the diameter of the graphite is 1mm. If the length of the pencil is 14cm, find the volume of the wood. (use  $\pi = 22/7$ ).

14. In the below Fig., ABCD is a trapezium in which  $AB \parallel DC$ . O is the mid point of BC. Through the point O, a line PQ  $\parallel AD$  has been drawn which intersects AB at Q and DC produced at P. Prove that  $\text{ar}(ABCD) = \text{ar}(AQP)$ .

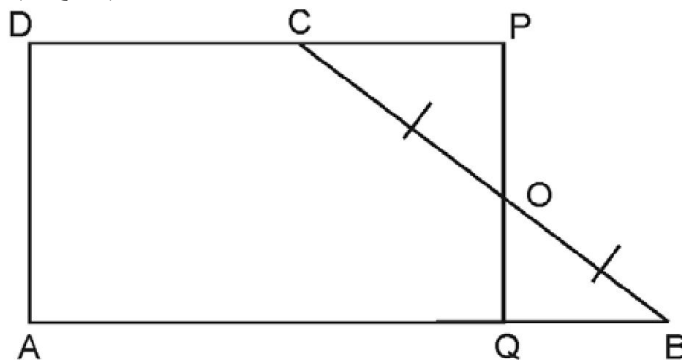

15. A heap of wheat is in the form of a cone, the diameter of whose base is 14m and height is 3m. Find its volume. The heap is to be covered by canvas to protect it from rain. Find the area of the canvas required.

16. Find mean of the following data:

Marks	10	11	12	13	14	15
No. of Students	6	3	4	5	7	5

17. OTBA Question from Linear Equation in two variables

18. The radius of a spherical balloon increases from 7cm to 14cm as air is being pumped into it. Find the ratio of surface areas of the balloon in the two cases.

19. A recent survey found that the ages of workers in a factory is distributed as follows:

<b>Age(in years)</b>	20 – 29	30 – 39	40 – 49	50 – 59	60 and above
<b>Number of workers</b>	38	27	86	46	3

If a person is selected at random, find the probability that the person is:

- (i) 40 years or more
- (ii) under 40 years

20. A die is thrown 400 times with the frequencies for the outcomes 1, 2, 3, 4, 5 and 6 as given in the following table.

<b>Outcomes</b>	1	2	3	4	5	6
<b>Frequency</b>	72	65	70	71	63	59

Find the probability of (i) getting a number less than 3. (ii) getting an outcome 6. (iii) getting a number more than 4.

### SECTION-D

**Question numbers 25 to 34 carry 4 marks each.**

- 21. Show that the line segments joining the mid points of the opposite sides of a quadrilateral bisect each other.
- 22. Construct a triangle ABC in which  $BC = 8\text{cm}$ ,  $\angle B = 30^\circ$  and  $AB - AC = 3.5\text{cm}$
- 23. In the below Fig., ABCD is a parallelogram and E is the mid point of AD.  $DL \parallel BE$  meets AB produced at F. Prove that B is the midpoint of AF and  $EB = LF$ .

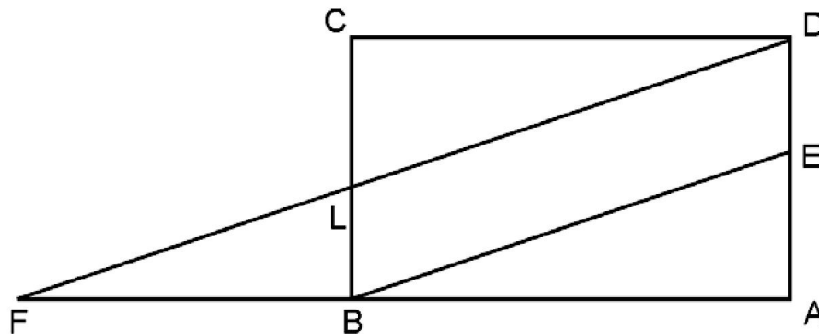

24. OTBA Question from Linear Equation in two variables

- 25. A storage tank is in the form of a cube. When it is full of water, the volume of the water is  $15.625\text{m}^3$ . If the present depth of the water is 1.3m, find the volume of water already used from the tank.
- 26. Diagonals AC and BD of a quadrilateral ABCD intersect at O in such a way that  $\text{ar}(\text{AOD}) = \text{ar}(\text{BOC})$ . Prove that ABCD is a trapezium.
- 27. In Fig., PQ is the diameter of the circle with centre O. If  $\angle PQR = 65^\circ$ ,  $\angle RPS = 40^\circ$  and  $\angle PQM = 50^\circ$ , find  $\angle QPR$ ,  $\angle PRS$  and  $\angle QPM$ .

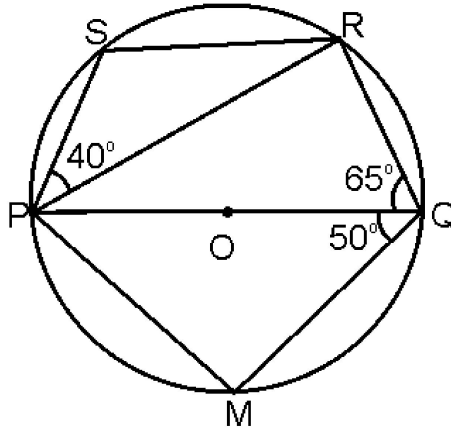

28. If two equal chords of a circle intersect within the circle, prove that the line joining the point of intersection to the centre makes equal angles with the chords.
29. The circumference of the base of a cone is  $\frac{220}{7}$  cm and its slant height is 13cm. Find the volume of the cone. (Use  $\pi = \frac{22}{7}$ )
30. A dome of a building is in the form of a hemisphere. From inside, it was white-washed at the cost of Rs 498.96. If the cost of white-washing is Rs 2.00 per square metre, find the (i) inside surface area of the dome, (ii) volume of the air inside the dome.
31. A random survey of the number of children of various age groups playing in a park was found as follows: Draw a histogram to represent the data above.

Age(in years)	Number of children
1 – 2	5
2 – 3	3
3 – 5	6
5 – 7	12
7 – 10	9
10 – 15	10
15 – 17	4

Why playing is important for the children?

